

**SYSTEMS, PRODUCTS
AND SERVICES
FOR WATERPROOFING
PROFESSIONALS**



DRYTECH SYSTEMS INCREASE YOURS WATERPROOFING ACTIVITIES

MORE QUALITY, MORE CUSTOMER SATISFACTION

Drytech offers unique waterproofing systems for both new construction and renovations.

All Drytech systems provide quality, time and money savings, and true maintainability over time.

Drytech systems are independent from weather conditions, allowing your business to operate at full capacity year-round. Expand your market, strengthen your image in terms of quality.

We can prove this claim because we deal with over 1,000 local job sites per year in our execution area.

WATERPROOFING CONSULTANTS AND DESIGNERS

The capital of a waterproofing company is its experience, and specialization.

Architects, engineers and building owners rely on us waterproofers for the success of their projects. They demand quality, trust and professional reliability.

With Drytech solutions, you offer not only products but systems from design to warranty.

Being the waterproofing design consultant allows you to position yourself in the market with respect, using your experience to allow contractors to take advantage of the economies of the Drytech system can help you do your job better, safer and faster.



**WE HAVE BEEN IN THE WATERPROOFING BUSINESS
SINCE 1963**

Drytech is specialized in a niche market, developing and manufacturing its own injection machines and products in Switzerland.

The swiss quality of our systems and equipments has been chosen by several waterproofing companies in different European countries.

Discover the full range of opportunities for your business and the training possibilities offered by the courses described on page 36.

SOLUTIONS	<i>NEW STRUCTURES UNDER TERRAIN, HYDRAULIC STRUCTURES, OPEN CAST AND UNDER- GROUND GALLERIES.</i>	DRYTECH WHITE TANK®	2
		INJECTABLE WATERSTOP TAPES FOR MOVEMENT JOINTS	9
		WATERTIGHT DIAPHRAGM WALLS	10
		FORMWORK HOLES	11
		WATERPROOF PUMP SHAFTS IN THE STALLS	12
		DRYFLEX EXPANDING ACRYLIC RESIN	14
		PRODUCTS	18
	<i>RESTORATION</i>	HIGH PRESSURE INJECTIONS FOR CONCRETE BASEMENTS	24
		INJECTIONS OF VEILING FOR BASEMENTS IN STONE, BRICK OR PREFABRICATED DOUBLE-LAYER MASONRY	26
		INJECTION MACHINES FOR ACRYLIC RESINS, CHEMICAL BARRIER AND PMMA	27
		EX POST GASKETS TO SEAL INFILTRATIONS IN SYSTEM PIPES, WITHOUT REMOVING CABLES	30
	<i>SURFACES</i>	DRYCOAT, CONTINUOUS AND WALKABLE COAT	32
	SERVICES	<i>TRAINING</i>	ENGINEERING DESIGN OF THE DRYTECH TANK
DRYTECH TANK INSTALLATION COURSE			
TRAINING COURSE FOR RESTORATION INJECTION TECHNIQUE			
TRAINING COURSE FOR DRYCOAT INSTALLATION			
CORPORATE	DRYTECH	WATERPROOFERS SINCE 1963	37

DRYTECH WHITE TANK®

FAST, ECONOMICAL AND RADON-PROOF WATERPROOF CONCRETE STRUCTURES

The Drytech White Tank is a waterproof concrete structure with construction details sealed by pressure by the DRYflex expanding acrylic resin.

The standards for the white tank in waterproof concrete recommend sealing the entire surface and the entire thickness of the underground structure.

They also require the adoption of waterproofing systems that allow maintenance to be carried out to ensure that the duration of the waterproofing coincides with that of the building.

The Drytech White Tank guarantees watertight integrity throughout the thickness of the structure and on the entire surface, allowing maintenance thanks to the re-injectable DRYflex resins, resistant to chemicals and non-damaging because they are protected by concrete.

Drytech concrete is impermeable to water according to the EN 12 390-8 standard.

The Drytech White Tank is the fastest, most practical, safe and guaranteed solution because:

- > it is a structural waterproofing, therefore it opposes the water and radon a barrier having the same thickness as the structure.
- > saves time and costs, because the waterproofing item disappears from the Gantt chart.
- > offers designers and companies the security of consultancy continues of Drytech Engineering.



WIN WIN SOLUTION

The Drytech White Tank is a waterproofing system that allows maintenance, thus reducing the business risk. It is practical and functional, it offers numerous opportunities for saving time and costs already during the design phase which give an added value to the system.

This is a key benefit for both you and your clients - architects, engineers and construction companies - who in turn can offer their contractors a waterproofing solution that meets all the requirements contained in the facility's use agreement, speeds up the whole construction and is affordable.

SAVINGS

The use of Programmed Cracking Inducers allows to reduce up to 45% of the anti-shrinkage reinforcement.

By being able to create larger casting stages, the times for reinforcing and disarming the reinforcement joints are reduced by 70% and the construction process by 30%. Furthermore, waiting times for laying and protecting the membranes are eliminated.

BUILD CUSTOMER TRUST

Drytech White Tank design allows you to build a relationship of trust in your role as waterproofing consultant with your clients.

Providing engineering advice on waterproof concrete formulation, creating a waterproofing concept with detailed solutions, makes your company an added value to your clients' projects.

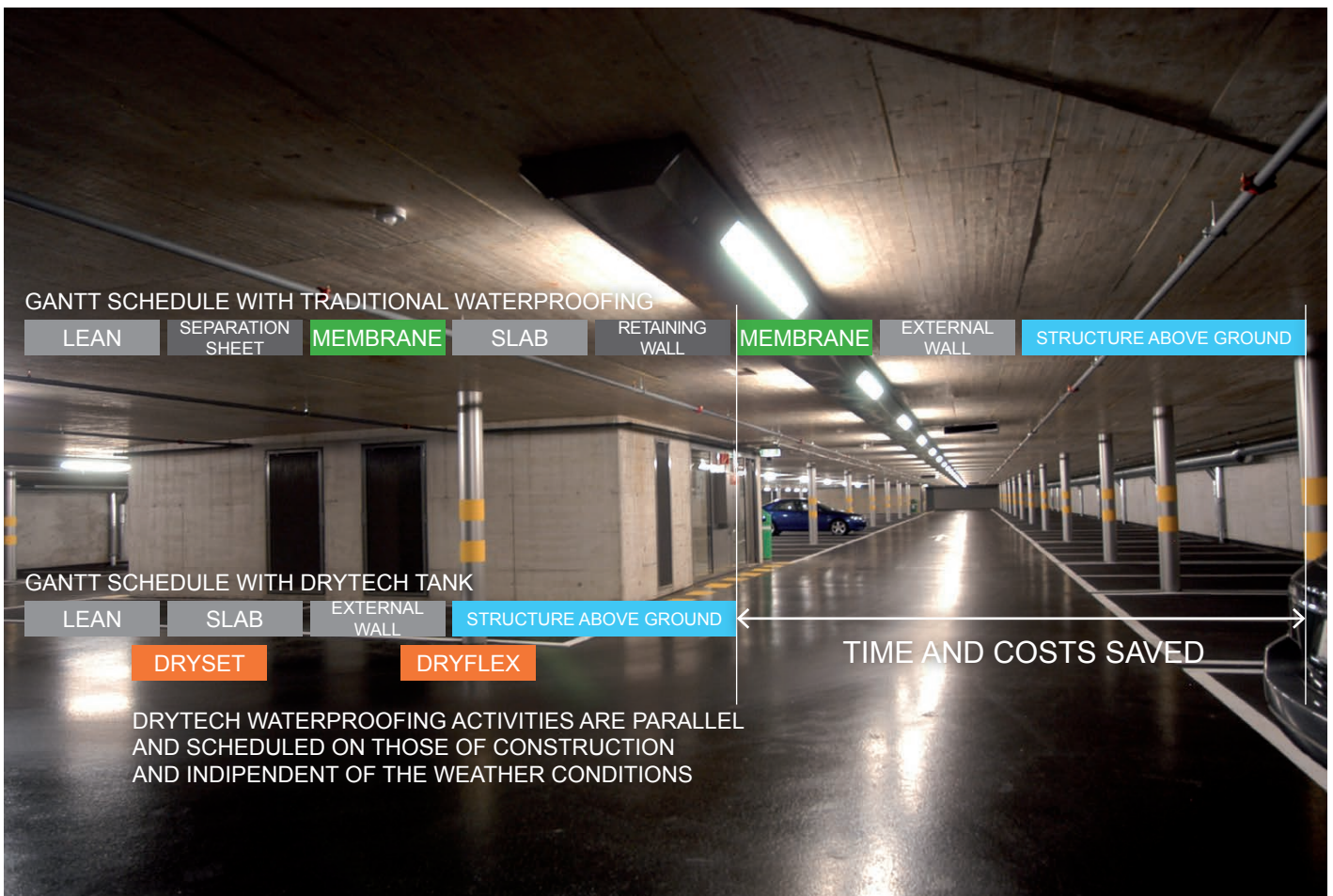

THE DRYTECH TANK IS A WATERPROOF RADON BARRIER

SAFER BASEMENTS

The Drytech Tank is a certified radon barrier. All DRYset and DRYflex system components have been tested and approved by the Institute of Building Materials of SUPSI (University of Applied Sciences of Southern Switzerland).

Gas permeability tests have been carried out on bonding points, cracks, construction joints, Drytech concrete, pipe penetrations and Drytech Tank compliance has been confirmed and meets WHO (World Health Organization), FOPH-BAG (Federal Office of Public Health) guidelines, the basic safety standards of the European Union and the SIA, which set the reference value for radon concentration at 300 Bq/m³ for rooms where people regularly stay, and the more restrictive limit of 100 Bq/m³ indicated in the Minergie-ECO requirements according to the Swiss USFP for main rooms.

TESTING ON CONSTRUCTIONS WITH THE DRYTECH WHITE TANK

In parallel with the laboratory tests, a series of field tests were carried out over 90 days on 14 objects, measuring radon concentration with dosimeters in basements without ventilation between December and February, using the Drytech White Tank in 14 buildings.

The empirical tests repeated the results of the experimental tests and confirmed the radon gas tightness of the Drytech Systems.



TESTING METHOD

SUPSI measured the waterproof diffusion coefficient of each individual material of the Drytech System: Drytech Waterproof Concrete, DRYflex Resin and bonded Hypalon and vulcanized Elastomer Rivet for formwork holes.

SUPSI has created a structure with Drytech consisting of two watertight cells separated from the material being tested.

The first cell was saturated with pressurized gas, exposing the specimen to radon. In the second cell, the quantity of gas that managed to pass by osmosis through the separation material was constantly measured.

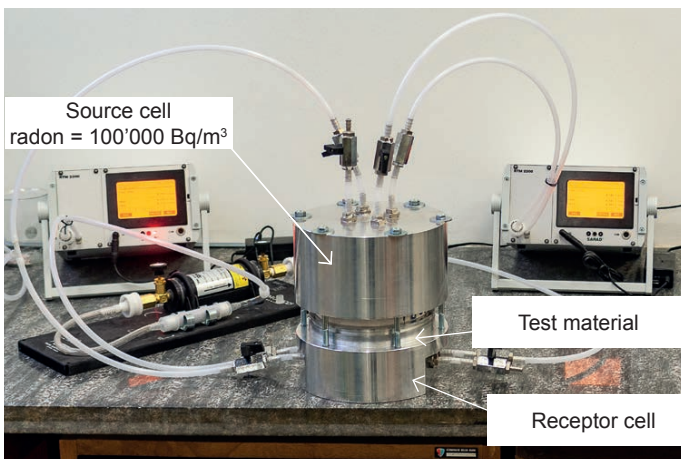

MINIMUM THICKNESS FOR RADON TIGHTNESS

The diffusion length R indicates how many millimeters (mm) the gas can penetrate the test material.

This number is multiplied by a safety coefficient of 3. The result (3.R) indicates the minimum material thickness required to ensure radon tightness.

	R [mm]	3•R [mm]	sVD [mm]
Drytech Concrete	36.7	110.1	≥ 250
DRYflex Resin	13.0	39.0	≥ 250

R Diffusion length of radon gas
 3•R Minimum thickness for impermeability
 sVD Drytech Tank minimum thickness

The test for the formwork hole closure system was based on a comparison of the gas exhalation rate in a monolithic concrete sample and a concrete sample drilled axially and closed with the Drytech System.

The exhalation rate measured for the test piece with the formwork hole was lower than that of monolithic concrete and therefore it has been successfully demonstrated that the Drytech formwork hole closure system is impermeable to radon gas.

	E [10 ⁻³ x Bq/s•m²]
Monolithic concrete	0.93
Formwork hole Closure Drytech	0.74

E Radon exhalation rate

SUPSI

Drytech Watertight Concrete

Concrete Type, CEM IV/A-V 32.5 N

$C_{RC} = 102'197 \text{ Bq/m}^3 / C_{RC} = 6'378 \text{ Bq/m}^3 \rightarrow D = 2.82 \times 10^{-9} \text{ m}^2/\text{s}$

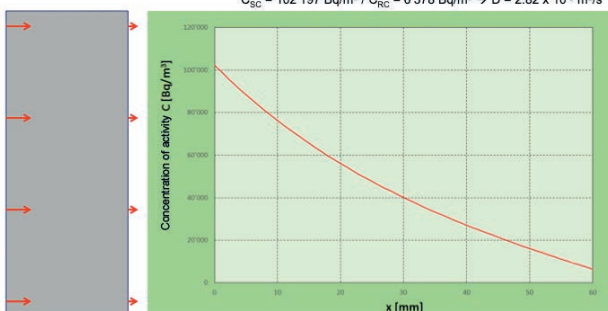

SUPSI

7

DRYflex resin

Mortar DryFlex Mortar

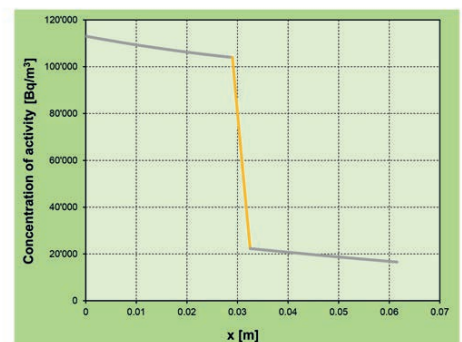
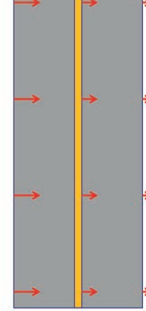

DRYTECH TANK®

TIME AND COST REDUCTION

DRYSET SYSTEM

DRYset system components serve as a transport medium for DRYflex waterproofing injection resin.

The installation of the DRYset profiles is coordinated with the activities of the construction company so that there is no waiting time.

DRYset components are weather-independent, save time and speed up the entire construction process.

INSTALLATION AND INJECTION BY A SINGLE RESPONSIBLE

The components are light and easy to handle and allow a good productivity, and the possibility for the specialist to be able to manage several small and large construction sites individually.

The quality of the installation, attention to detail and experience are reflected in the success of the waterproofing.

The specialist must be properly trained and quality oriented, which brings with it the success of the waterproofing and the company's reputation.

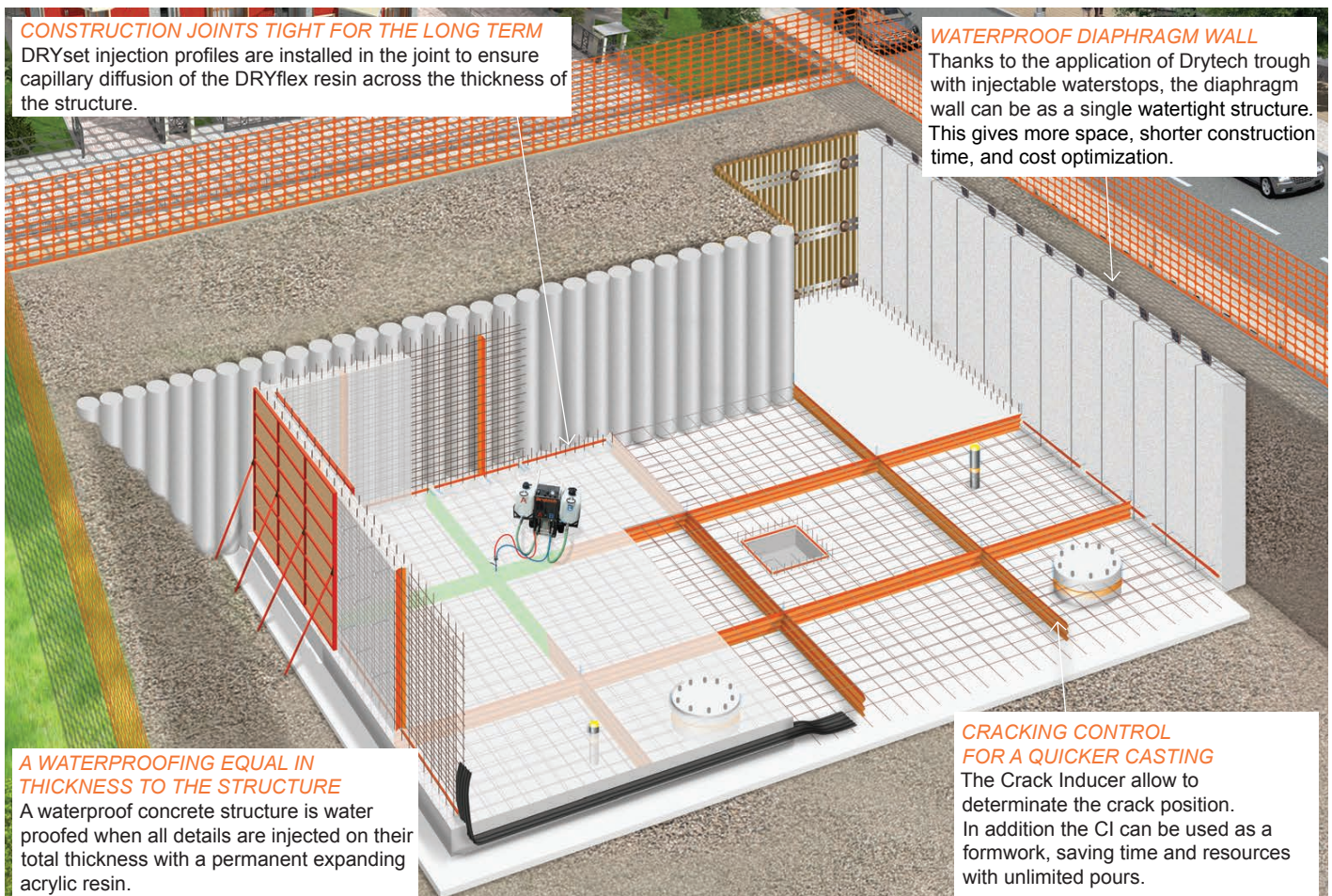

DESIGN WITH CRACKING ELEMENTS PROVIDES FASTER CONSTRUCTION AND OPTIMIZATION OF THE IRON REINFORCEMENT COSTS.

Reduced concrete shrinkage areas with the help of Crack Inducers allow for larger casting stages, with a reduction in construction time of up to 30%, a reduction in distribution reinforcement of up to 45% and a reduction in shrinkage cracks of 96%.

Crack Inducers act as construction joints, structural and shrinkage reinforcement is not weakened and is pass-through.

DRYset CIs reduce formwork time for arm and disarm the construction joints by 70%.

The system is independent of weather conditions and eliminates the time spent waiting for a membrane to be installed and protected.



DRYTECH TANK®

COLD JOINT / CONSTRUCTION JOINT

DRYSET INJECTION CHANNEL FOR CONSTRUCTION JOINTS

The DRYset injection channel has been developed with a semirigid material to allow the installation with adherence on the surface of the joint. The filter foam allows the prevention of infiltration of cement mortar and the diffusion of DRYflex 1 injection resin over the entire thickness of the structure.

The injection that is made after 60 days from the end of the construction of the underground structure seals the joints and adjacent gravel pockets over the entire thickness.

Lightweight, easy to handle and cut.

Independently of weather conditions.

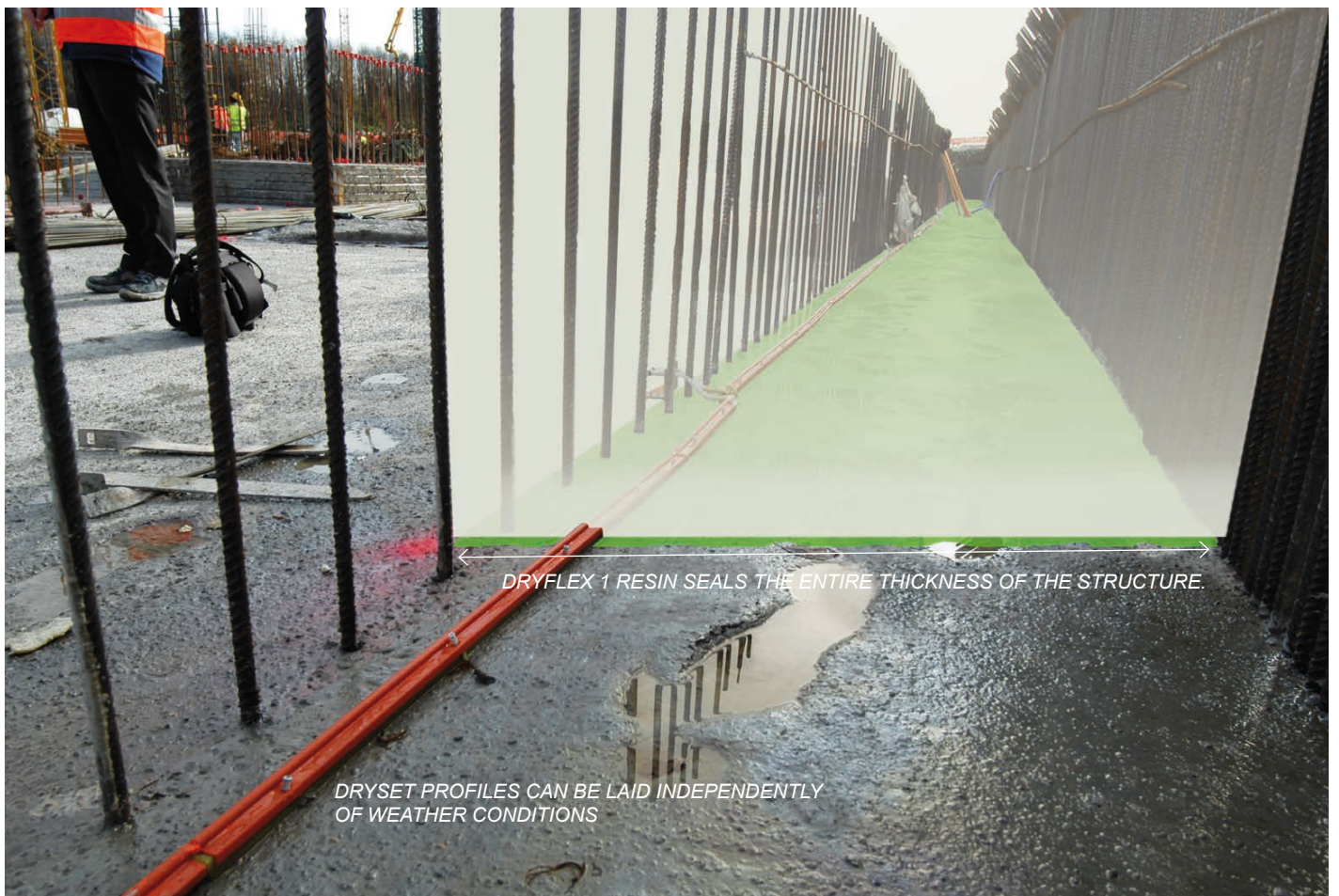
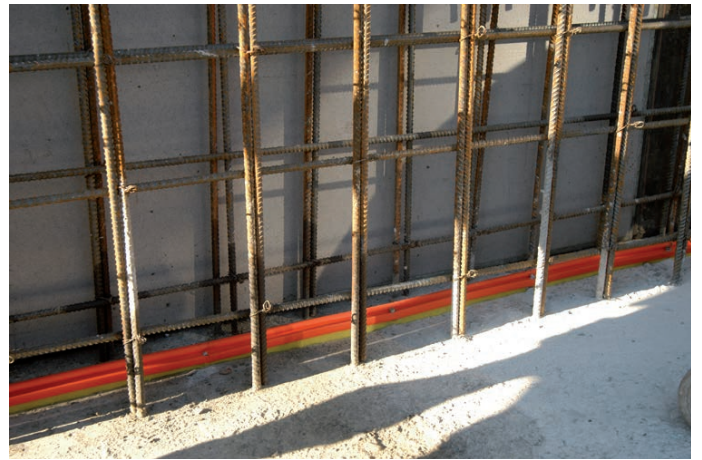

MOVEMENT JOINTS

THE EXCELLENT SOLUTION FOR UNDERGROUND MOVEMENT JOINTS EXPOSED TO WATER PRESSURE

The DRYset Waterstop Tape is the only system that not only absorbs thermal and settlement movements, but also seals out the bypassing and capillary effect of water.

The tape section includes two pre-drilled tubes for resin diffusion inside the movement joint.

Waterstop tapes for expansion joints can be internal or external and the injection of DRYflex definitively solves the bypass and capillary effect of water.

The DRYset Waterstop allows cost-optimized maintenance through post-injection.

External injectable waterstop tape expansion joint

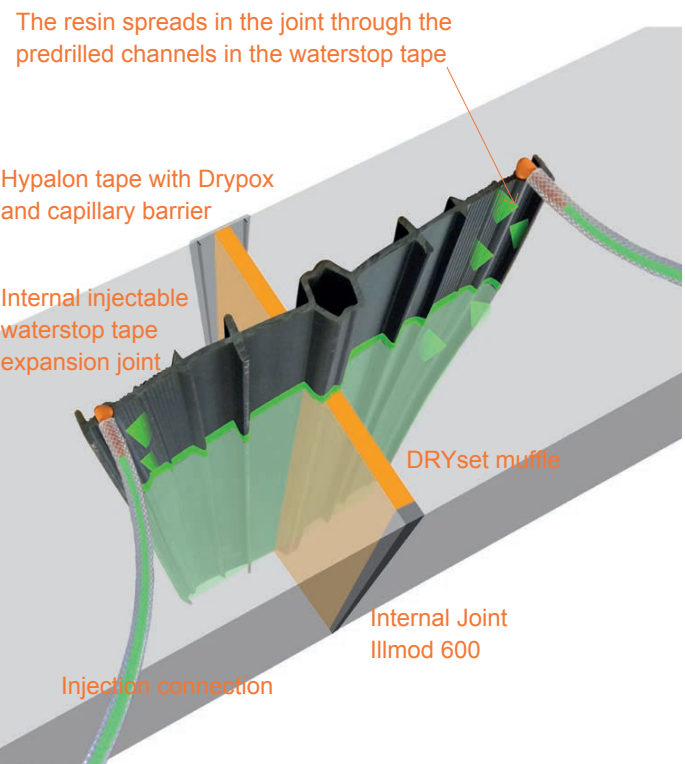
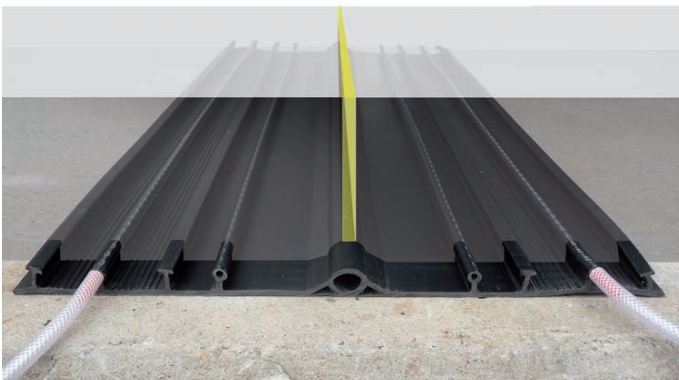

DRYTECH TANK® WATERTIGHT DIAPHRAGMS

MORE INTERIOR VOLUME AND MERCHANTABLE SURFACE

The exclusive injectable Waterstop tape developed by Drytech allows the containment wall to be used as a single watertight element.

The joint system combined with waterproof concrete, injections of anchor bolts, vertical and horizontal joints between slab-diaphragm, and gravel pockets, saves time and several work processes.

A white DRYcem osmotic cement allows to improve the aesthetic impact and guarantees a constant accessibility for future maintenance, ensures the water tightness and durability agreed in the usage agreement.

Injectable waterstop tapes are attached to removable side sheet piles that act as formwork sidewalls.

The sheet pile creates the structural recess and simultaneously protects the tape during adjacent excavations.

Injection of the waterstops takes place at level 0 from the incorporated injection tubes divided into sectors and injection levels.

The sealing of the waterstop bypassing effects always takes place with DRYflex 2 resin. Only by injections it is possible to prevent infiltration during excavation and to guarantee a watertightness.

BENEFITS

- > More interior volume and merchantable surface area.
- > The installation of drainage systems, leveling plasters, membranes, protective blankets, and concrete retaining wall is avoided.
- > The application of an osmotic cement such as DRYcem White improves the aesthetic impact.
- > Accessibility allows for maintenance and durability in operation.

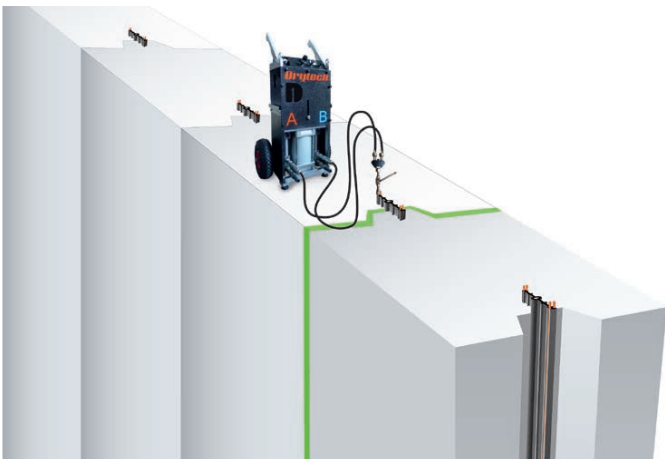

DRYSET RIVET FOR WATERPROOF FORMWORK HOLES AN ELEGANT AND FAST SOLUTION

CLEAN HOLE BY REMOVABLE TUBE

DRYset Pipe is an accessory in place of the conical cover that connects to the formwork spacer lining pipe. After the concrete has hardened, it is extracted leaving an ideal hole which is sealed with the rivet. The accessory can be used several times.

The articulated head allows DRYset Pipe to compensate for any misalignments of the tie rod, guaranteeing the perfection of the hole edge.

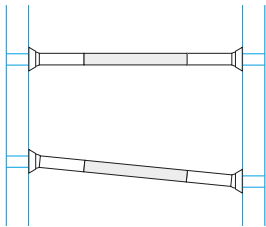

Length 8 cm inside Ø 21mm
Formwork tension reinforcement max. Ø 15 mm
For spacer lining tube with an interior Ø 22 mm

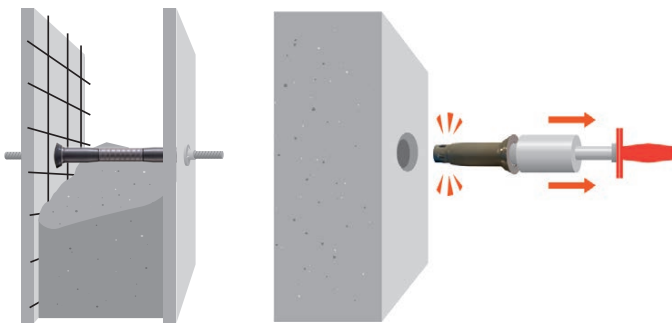

EXPANDING RIVET FOR CLOSING THE FORMWORK HOLE

DRYset Rivet allows a fast and safe closure of formwork holes. It seals thanks to the pressure it develops against the surface of the hole.

The DRYset rivet made of vulcanized thermoplastic elastomer is weather-independent and does not require any waiting time for the hardening of any adhesive.

The depth of sealing is 5 cm: with the use of Drytech concrete you get a maximum penetration of 15 mm and a triple safety factor.

The watertightness is guaranteed up to a water pressure of 10 bar.

Length 8.5 cm outside Ø 27 mm < (10 bar)	C11
Length 5.0 cm outside Ø 27 mm < (3 bar)	C12

C1 1 and 2: Waterproof class

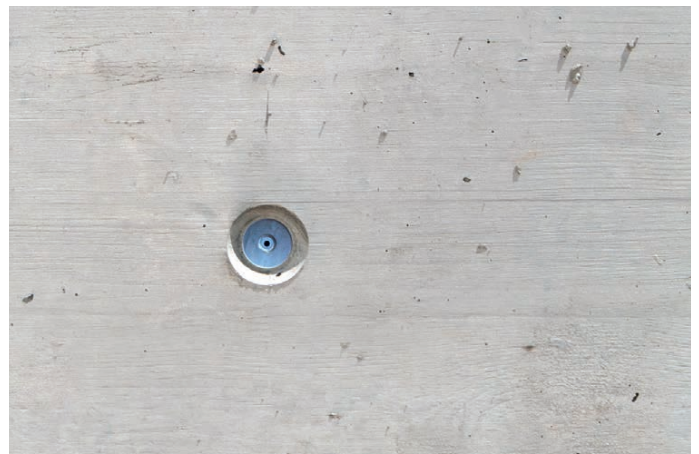
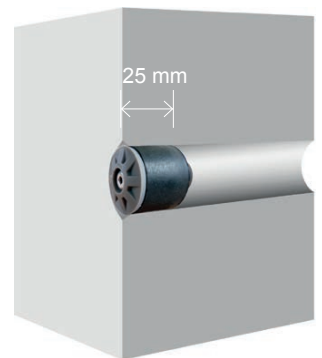
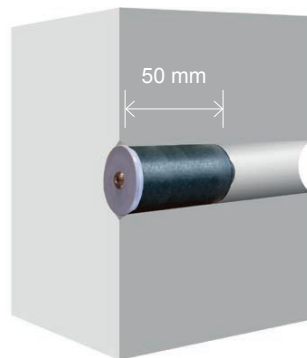

DRYTECH TANK® WATERPROOF PUMPING WELLS

RESISTANT TO WATER PRESSURE AND WATERPROOF

DRYset waterproof wells allow you to have the grabbing points inside the concrete bed.

The pump wells for lowering groundwater have been developed with an O Ring and a fast closing system capable of counter-acting water pressures.

The DRYset sleeve and side anchors are used to seal and secure the connection to the waterproof concrete.

The lid can be equipped with a gate valve to allow connection to the pump pipe to lower the groundwater level in case of maintenance or expansion.

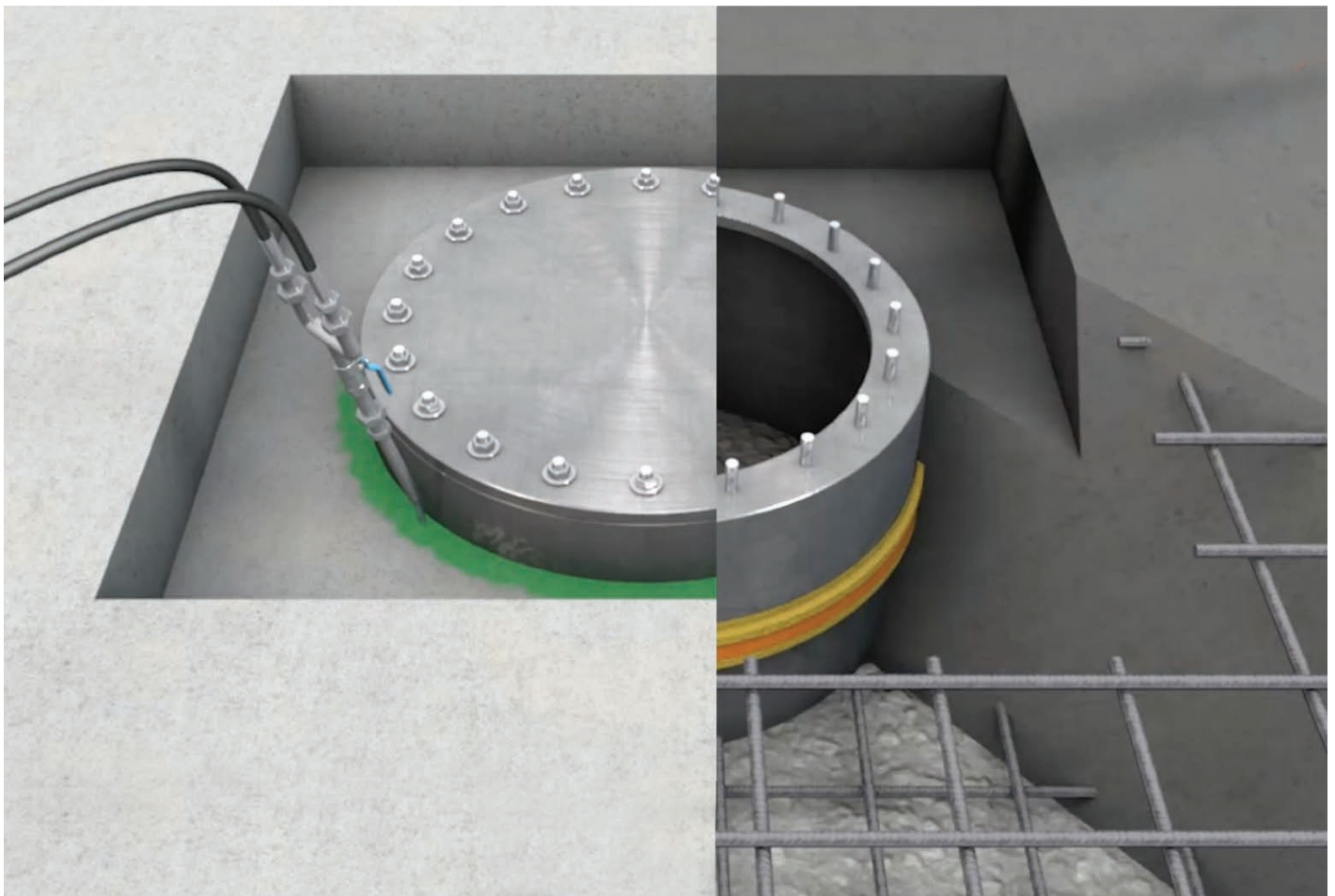

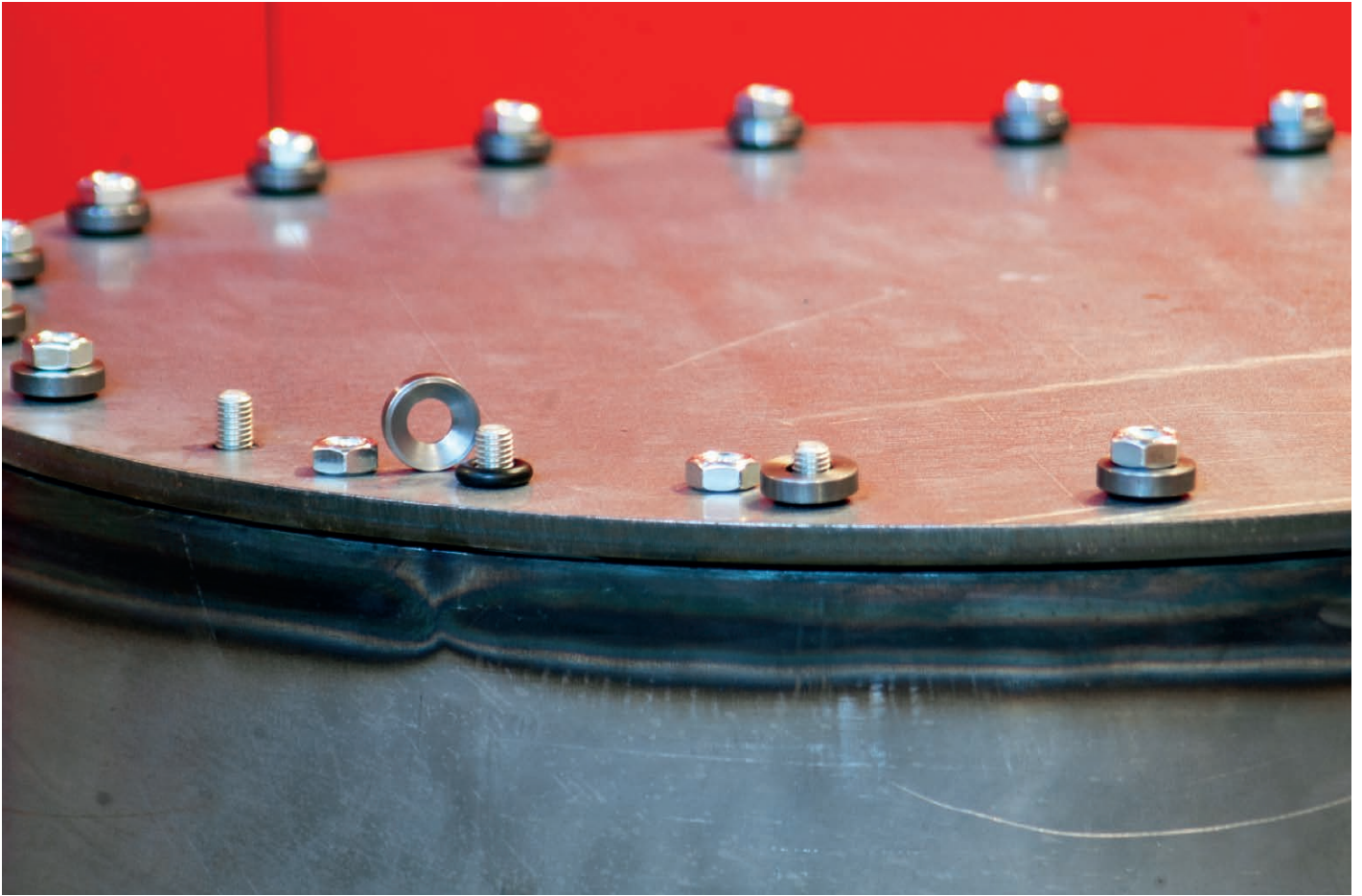

DRYTECH WHITE TANK® DRYFLEX RESIN

The waterproofing is created by a watertight concrete according to EN 12 390-8 with a maximum penetration of 12-15 mm, and the installation of the DRYset elements, through which the injection with DRYflex 1 acrylate seal construction joints, cracks, cast elements, gravel pockets sealing the entire thickness of the critical points of the structure.

After polymerization, the Dryflex 1 resin has the consistency of a flexible hydro-expansive gel, which allows a systematic post-injection that seals the thickness of the structure and the surrounding treated areas by pressure.

WATERPROOFING BY PRESSURE

The resin forms an elastic gel within just a few minutes and, thanks to its self-expanding nature, forms a pressure-seal within the crack.

This reactive and reversible swelling remains constant over time.

DRYflex resin is dyed to distinguish it from water during the injection operations. The colour disappears a few minutes after injection and the resin becomes colourless leaving no trace on the surface injected.

Injection is possible and effective even in the presence of pressurized water and is not affected by atmospheric conditions.



1 Installation
2 Injection
3 Re-injection with pressure
4 Pressurize

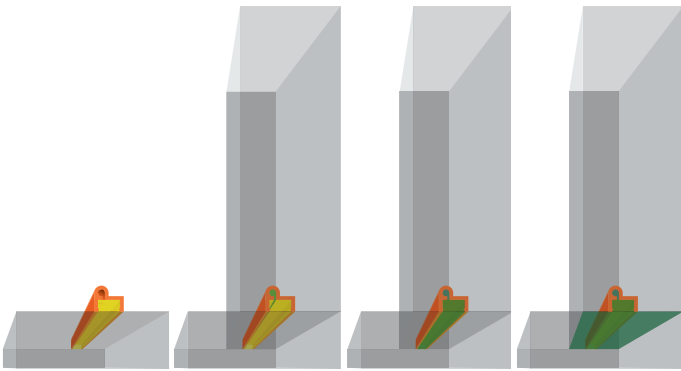

1 Installation
2 Injection
3 Re-injection with pressure
4 Pressurize

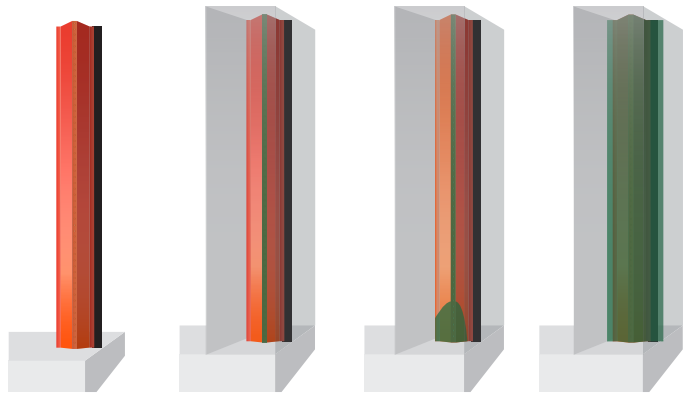

DRYFLEX RESIN

THE MAIN COMPLIANCES WITH EN 1504-5 : 2013

The active sealing principle of the injection gel is a flexible hydro-expansive waterproofing, which seals with the force of pressure against the internal surfaces of the treated areas.

The green color of the resin changes to a dark violet when the dilution with water is risking affecting the quality of the jellified resin.

The alimentary colorant is not UV resistant and neutralizes in a short time without staining.

ECOLOGICAL ASPECTS, AIR POLLUTION CONTROL, HEALTH AND QUALITY

DRYflex the resin where ecological, health and quality take first place.

Ecological

Because the acrylate resin is solvent-free, the polymerization gel can be disposed of as food waste, and the WGK 1 toxicity class is not dangerous for drinking water and groundwater.

Health

With a neutral pH of 6.7-7.0, it does not harm skin and hands even in daily use and does not develop toxic gases in the event of smoke, fire or handling.

According to current European transport regulations, DRYflex resin is classified as a non-dangerous substance.

Quality

The total absence of corrosion in case of cracks, nests of gravel and cavity fills and its setting times quick < 6-8 seconds even in the presence of water are the characteristics that allow DRYflex to gel with a water / resin ratio 1:7, reducing working times and excessive resin consumption.



DRYflex 1 AND 2 COMPLIANCES

REQUIREMENTS	NORM	DESCRIPTION
Reactivity	EN ISO 9514	Gelation time between 6 sec and 25 min
Durability, expansion and expansion	EN 14498	The expansion reaches a constant level between 35% max. 65% of the initial mass.
Durability, sensitivity to wet / dry cycles	EN 14498	After 20 wet / dry cycles with a conditioning regime at 50 °C, the mass must be equal to or > 35% of the initial mass.
Corrosion behavior	EN 480-14	Without corrosive effects
Behavior to fire	BS6853	Smoke emission: <0,0026 m ² /g (Limit < 0,05 m ² /g) The London Underground Standard 1-085: A1
	BS EN ISO 4589-2	Flammability: oxygen index >90% (Limit > 30%) BS EN ISO 4589-2: 1996: Part 2
Compatibility with drinking water	BS 6920-1: 2000	Odor and taste of water: <1 Appearance of water: color <0.6 Turbidity: <0.09 Presence of micro-organisms: <0.4 mg / l Content of substances harmful to public health cell morphology: satisfactory color of the culture medium: normal confluence of the monolayer: 100% metal release: compliant with the standard
Toxicity	VwVws 17/5/1999	Water hazard class: (WGK) 1 (1 = low risk; 5 = high risk) Mammalian Toxicity LD50: > 2000 mg / kg Aquatic Toxicity EC: > 1000 mg / kg Bio-degradability: Biodegradable according to OECD 301 B Bio-accumulability: not bio-accumulative
	DS/EN 1484	cTap 3rd migration = 0.028 mg/L Toc Limit 0.5 mg/L = 0.0013 mg/L Acrylamid Limit 0.3 mg/L = 0.00013 mg/L

NOT OXIDIZING

Many acrylic hydrogels favor the corrosion of the reinforcement iron because they isolate it from the passivating effects of the oxidation guaranteed by the alkaline components of the cement (down). EN 480-14

The Institut für Bauforschung of the University of Aachen has certified through its tests that the DRYflex resin does not oxidize the reinforcement either in the cracks or in the gravel nests (down). EN 480-14

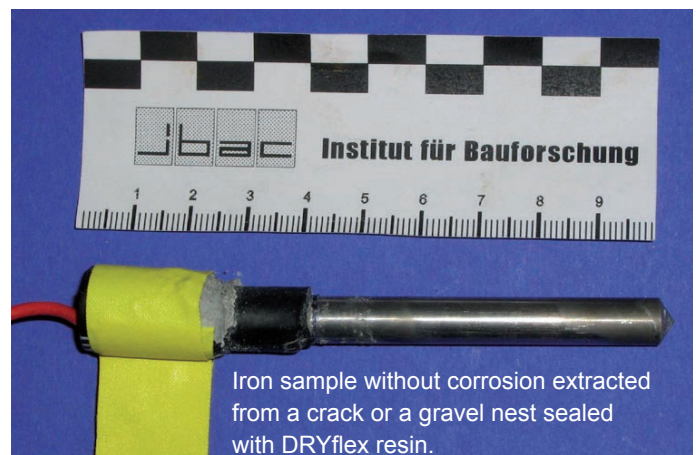
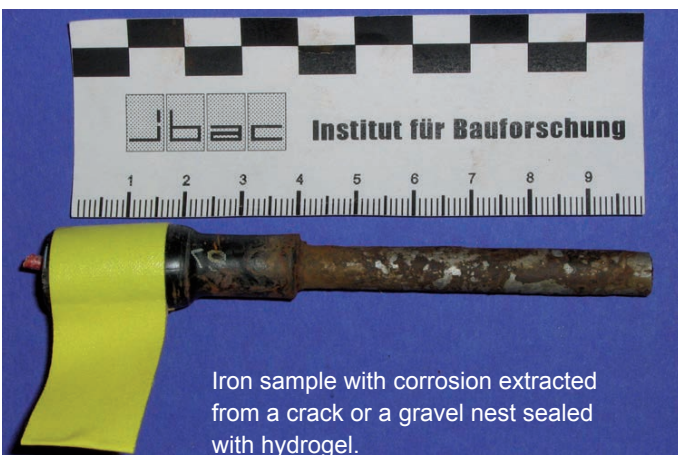

DRYTECH TANK PRODUCTS

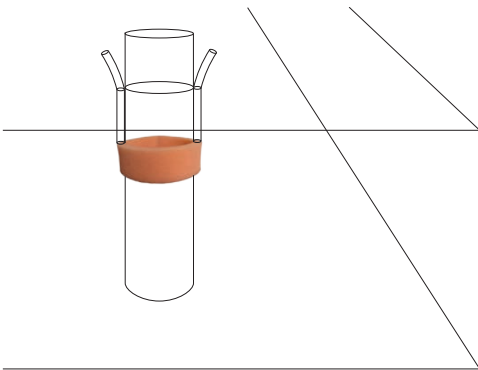

DRYSET INJECTION SLEEVE FOR PASS-THROUGH ELEMENTS OR PENETRATIONS AND DILATION JOINT INSERTION.

The Drytech sleeve filter foam avoids the cement mortar from plugging.

It's applied to all concrete through-elements, shafts and pipes, or for insert in expansion joints for a future maintenance.

The filter foam is attached to the elements with an adhesive tape and a zip tie, connected to the injection hoses and then injected with DRYflex.

It's independent of weather conditions

Length 200 cm / width 6 cm / thickness 1.5 cm

Length 200 cm / width 20 cm / thickness 2.0 cm

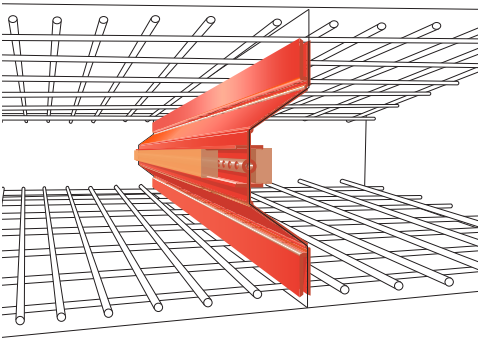

DRYSET INJECTABLE CRACK INDUCER

DRYset for Pre-designed shrinkage cracking, act like construction joints, can be used as disposable formwork.

The benefits:

Smaller division of the shrinkage fields can optimize the reinforcement content up to 45%.

Larger fields can be cast, which shortens the construction time.

Time of the formwork removal of construction joint can be saved.

Shrinkage casting stages can be avoided.

The applied filter foam avoids the cement mortar from plugging the channel and at the same time allows the resin to be distributed over the thickness of the joint or planned shrinkage crack.

Independent of weather conditions

Concrete thickness Lenth 250 cm width 13 cm for up to 25 cm

 Lenth 250 cm width 20 cm for 30 cm and >

Delivery: (w 13 cm) pallet with 56 pack = 700 m

 (w 20 cm) pallet with 40 pack = 500 m

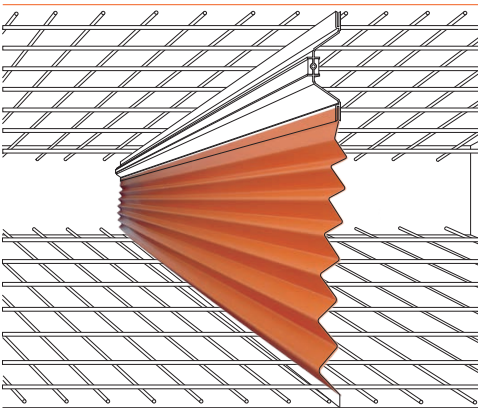

COMPENSATION PANEL FOR CRACK INDUCERS FOR HIGH SHEAR REQUIREMENTS

Z-panel in HDPE for compensation of Crack Inducers or for disposable formwork.

Independent of weather conditions

Length 260 cm Width 52 cm Thickness 2 mm

Supply: pallets of 100 pieces

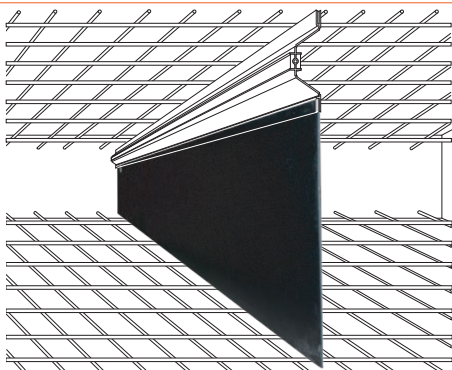

COMPENSATION PANEL FOR CRACKING ELEMENTS

Plain panel in HDPE for compensation of Crack Inducers or for disposable formwork.

Independent of weather conditions

Length 260 cm Width 100 cm Thickness 2 mm

Supply: pallets of 100 pieces

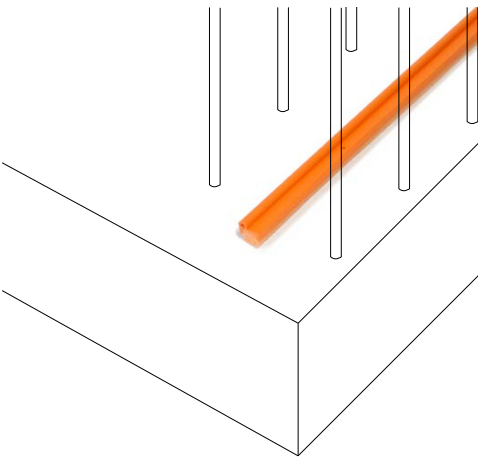

DRYSET INJECTION CHANNEL FOR CONSTRUCTION JOINTS

The DRYset injection channel has been developed with a semirigid material to allow the installation with adherence on the surface of the joint.

The filter foam allows the prevention of infiltration of cement mortar and the diffusion of DRYflex 1 injection resin over the entire thickness of the structure.

The injection that is made after 60 days from the end of the construction of the underground structure seals the joints and adjacent gravel pockets over the entire thickness.

It is lightweight and easy to handle and cut
Weather resistant

L 200 cm W 3 cm H 2.5 cm
Delivery: Pcs. 50 x Pallet Pc x 53 = 3150 m

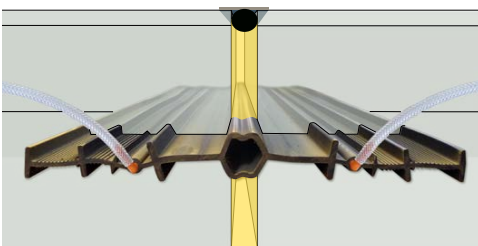

INTERNAL INJECTABLE WATERSTOP TAPE FOR EXPANSION JOINTS

The excellent solution for underground movement joints exposed to water pressure.

The only system that not only absorbs thermal and settlement movements, but also seals out the bypassing and capillary effect of water.

Waterstop tapes can be internal or external and the injection of DRYflex definitively solves the bypass and capillary effect of water.

Internal injectable waterstop tape for expansion joint.

Width 33 cm Thickness 5 mm
Delivery: Rolls 25 m.

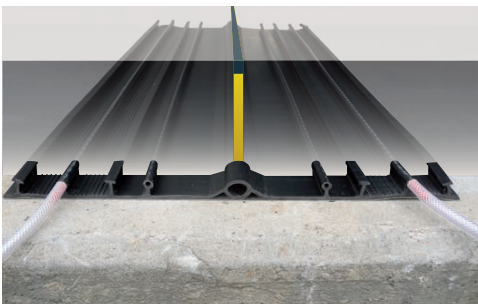

EXTERNAL INJECTABLE WATERSTOP TAPE FOR EXPANSION JOINTS

Width 52 cm Thickness 5 mm

Delivery: Rolls 10 m.

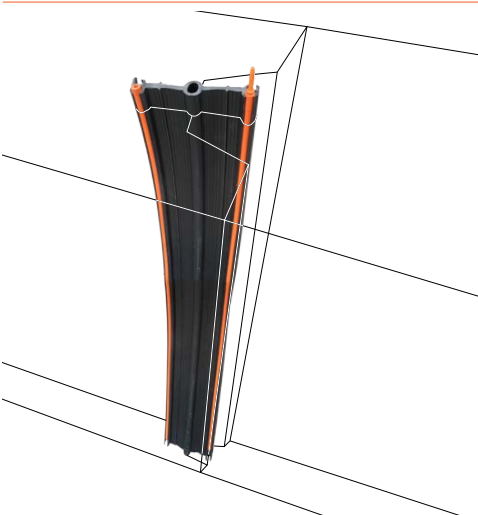

WATERTIGHT DIAPHRAGM

More volume and surface area = added value.

The unique injectable Waterstop tape, seals vertical construction joints in the containment walls.

It is measured -2 meters from the bottom elevation of the slab to the zero level and is manufactured in one customized piece.

It is installed on the side sheet pile that acts as a removable formwork sidewall.

The injection divided in sector by the injection tubes of the waterstop tape, takes place from level 0 and seals the bypassing effects of water that would cause infiltration during the excavation phase ensuring the watertightness of the joints over time.

Independent of weather conditions

Tape width 16 cm / Thickness 8 mm

Delivery: Made to measure according to order.

DRYTECH TANK PRODUCTS

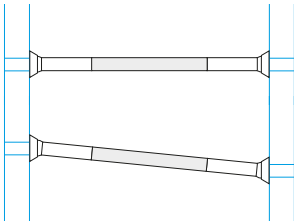

Wall 250 mm



Wall >250 mm



DRYSET PIPE FOR FORMWORK HOLE.

DRYset Pipe is an accessory that goes to the construction company as a replacement for the spacer pipe cones.

The system allows removal from the hardened concrete, creating a clean and smooth formwork hole.

The DRYset Pipe PA polyamide spacer pipe cones can be reused several times.

Length 8 cm inner Ø 21mm

Formwork tension rebar max. Ø 15mm

Suitable for spacer pipe with inner Ø 22mm

Supply: Pack of 2000 pcs.

Waterproofing Class 2



Waterproofing Class 1



DRYSET RIVET FOR SEALING THE FORMWORK HOLE.

The DRYset rivet made of vulcanized thermoplastic elastomer is ideal for sealing the formwork hole quickly and Independent of weather conditions and with no waiting time for hardening.

The depth of sealing is up to 5 cm with a triple safety factor for average concrete with a water penetration depth of 15 mm.

Sealing is guaranteed up to 10 bar water pressure.

Length 8.5 cm outside Ø 27 mm < (10 bar)

Length 5,0 cm outside Ø 27 mm < (3 bar)

Supply: Carton of 200 pieces.

Bins of 200 or 400 pieces).

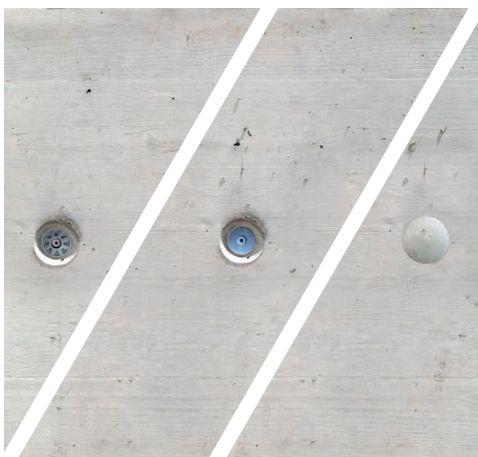

DRYCEM RIVET COVER

Cementitious formwork hole cover for show wall to cover the DRYset Rivet.

3 gray tones light gray / concrete gray / dark gray

Supply: On request from concrete sample



DRYFLEX 1

waterproofing principle: WP Hydro expansive Swelling Pressure

2 component 1:1 acrylate resin WP to the injections of WT-concrete structures for injection profiles in construction joints, crack elements and pipe muffle in damp, wet, dry with or without running water.

Crack width changes:	ΔWc : up to 25%
Crack width:	> 0.05 mm
Water tightness:	$^3 7 \times 105 \text{ Pa}$
Water absorption with constants volume and weight:	< 35 %
Sensitivity wet/dry cycle:	Initial size
Reaction time at 20°C:	≤ 10-120 seconds
Reaction time at 20°C with dilution: resin / water 1:3:	≤ 40 seconds



DRYFLEX 2

waterproofing principle: WP Hydro expansive Swelling Pressure

2 component acrylic resin for waterproofing through cracks, construction and movement joints, pass-through elements, gravel pockets as well as voids in concrete, prefabricated concrete elements such as Tubbing elements in wet, damp structures with or without water pressure.

Crack width changes	ΔWc : up to 25%
crack width	> 0.05mm
Water tightness	$^3 7 \times 105 \text{ Pa}$
Water absorption with constants volume and weight:	< 30 - 65%
Sensitivity wet/dry cycle:	Initial size
Reaction time at 20°C:	≤ 10 seconds
Reaction time at 20°C with Dilution: resin / water 1:3:	≤ 40 seconds
Dilution: resin / water 1:5:	≤ 120 seconds

DRYTECH TANK PRODUCTS



Tank 20 L

Tank 5 L

Jar 750 g

DRYflex 3

Waterproofing principle: WP Hydro expansive Swelling Pressure

IP 2-component 1: 1 acrylamide resin for injections of waterproof concrete structures of industrial wastewater treatment plants.

Crack width changes:	ΔWc : up to 25%
Crack width:	> 0.05 mm
Water tightness:	$\approx 7 \times 10^5$ Pa
Water absorption with constants volume and weight:	< 35 %
Sensitivity wet/dry cycle:	Initial size
Reaction time at 20°:	$\leq 10-120$ seconds
Reaction time at 20° with dilution: resin / water 1:3 :	≤ 40 seconds



Tank 5 L

Jar 750 g

DRYflex 4

Waterproofing principle: WA Waterproofing by adhesion.

Two-component PMMA-based resin for waterproofing and restoring cracks above ground in walls exposed to sunlight.

Density at 20 °C	0.96 g / cm ³
Viscosity at 20 °C (Brookfield)	15 ± 5 mPas * s
Polymerization time + 5 °C	30 min. / + 20 ° C 15 min.
Tensile strength	65 N / mm ²
Flexural strength	50 N / mm
Shear strength	+ 5 ° C Concrete failure after 5 h / + 20 ° C Concrete failure after 3 h

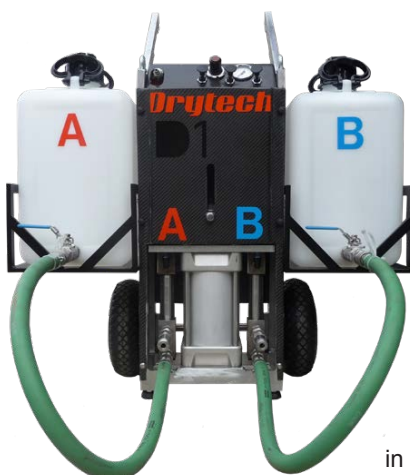

D1 INJECTION MACHINE 2 COMP. MIX RATIO 1:1

Injection machine for acrylics including 2x12 m hoses and mixing battery.

Weight 23 kg Adjustable injection pressure from 20-180 bar.



Heating system for injections in environments with temperatures -2÷ 12 °C



Tank 20 L

Tank 5 L

DRYveil

Waterproofing principle: CF Consolidation with slightly flexible adhesion.

Stabilizer and waterproofing injection based on sodium silicates for veiling restoration of structures against the ground.

After injection, the treated soils may have permeabilities lower than 10^{-8} m/s.

DRYveil increases the mechanical resistances and allows to bring cohesion to the ground.

DRYveil has a reaction kinetics that allows a good control of the injection time.

- Permeability after treatment below $10E^{-8}$ m / s.
- Biodegradable and non-toxic for aquatic species
- Low viscosity of the mortar (close to water)
- Resin with high penetration capacity, free from toxic materials or heavy metals.

Mixing: Part A 30% + Part B 3% + H₂O 67%

Time activation: 10 - 20 minutes.



Tank 20 L

Tank 5 L

DRYsoil

Waterproofing principle: CR Consolidation with rigid adhesion.

Consolidating and waterproofing injection based on sodium silicates.

Consolidation aims to increase the mechanical resistance of the soil.

DRYsoil can be used alone or in combination with DRYflex 2 to increase waterproofing.

Consolidation is obtained by injecting a silicate grout which, once hardened, increases the mechanical resistance of the soil from 3 to 10 MPa.

- Very low viscosity and penetration in fine soils
- Adjustable setting times for easy processing
- Adjustable compression resistance
- Biodegradable and free from toxic materials or heavy metals.

Compressive strength

RCK N / mm² 3.00

Test description

Specimen made with: Standard Sand EN 196-1
 Origin France
 +
 DRYsoil 530 kg/m³

Mixing: Part A 60% + Part B 15% + H₂O 25%

Time activation: 10 - 20 minutes.

DRYTECH RESTORATIVE INJECTIONS WITHOUT INTERRUPTION OF THE STRUCTURE USE WITH IMMEDIATE TIGHTNESS TEST.

STOP WATER WITHOUT INTERRUPTION OF THE STRUCTURE USE

Restoration with DRYflex 2 injections in underground structures or tanks is done from the inside or accessible side. Excavation, demolition and disruption are rarely necessary.

Drytech remediation systems are used to solve a wide range of problems: from small domestic leaks to cracks in dams.

BENEFITS

Non-invasive:

The injection is done from the accessible side, in most cases no demolition or excavation is needed.

Immediately verifiable:

Thanks to the acrylic resin and the adjustable curing time up to 6 seconds, the work of grouting the cracks is avoided and the effectiveness of drilling ability, injection filling and water flow elimination is immediately verifiable.

Waterproofs with hydro-expansive strength:

Acrylic resins seal by the force of pressure against the inner surfaces of the treated areas do not require adhesion, water and dirt is pushed out by the injection pressure.



THANKS TO THE NIGHT WORK, THE SUBWAY WAS ABLE TO BE RENOVATED WITHOUT SERVICE INTERRUPTIONS.

During the infiltration restoration of the Piola / Lambrate subway section in Milan, the water level had risen to the platform.

All injections were carried out in the presence of water pressure. The contract established the payment of the injection works depending on the degree % of watertightness of the intervention.

The watertightness at the end of the work was 100% and remained effective over time.



DRYTECH RESTRUCTURING VEIL INJEKTION

EXTERNAL WATERPROOFING WITHOUT EXCAVATION

Veil injections are made into humid, wet, dry or stagnant water structures:

- 1) Injections into compartmentalized sectors or joints of a waterproofing system with synthetic membranes.
- 2) This can be interstitial cavities between the substrate and the waterproofing damaged membrane or with no bond.
- 3) Waterproofing of walls in the ground, where the cavity between the underground exterior of a wall and the ground by injections to create a veil (or a coating covering the entire area) to seal the external surface.

SYSTEMS

DRYflex Veil:

The veil is created by perforating the wall in contact with the ground through which the sodium silicate resin is injected, creating an eco-friendly waterproof membrane with a stabilizing effect between the external surface of the wall and the ground.

DRYflex 2:

However, the veil injection is done with an environmentally friendly acrylate gel.



D1 INJECTION MACHINE

LIGHTWEIGHT, PERFORMING AND WITH MINIMAL MAINTENANCE

23 KG + 180 BAR

Drytech restoration systems are based on injecting DRYflex expanding resin from inside underground structures: no excavation or demolition are required and, above all, there is no impact on a structure's activities.

Drytech Restoration Systems are used to resolve a complete range of problems: from small domestic leakage to cracks in dykes.

D1: LIGHT AND POWERFUL

The super-light Drytech D1 injection machine allows the intervention of the single operator, respecting their health and supporting their productivity.

ADVANTAGES

- > With a weight of only 23 kg, it can be operated by only one person, and its chassis and wheels allow ideal movement on all surfaces, including up and down stairs.
- > Adjustable injection pressure 20-180 bar.
- > Mixing battery equipped with cleaning solution.
- > Capacity tanks: 50 liters.
- > Pumping capacity 3-4 liters/minute.
- > On request it is possible to install a consumer control.
- > Available to order machine and material heater.

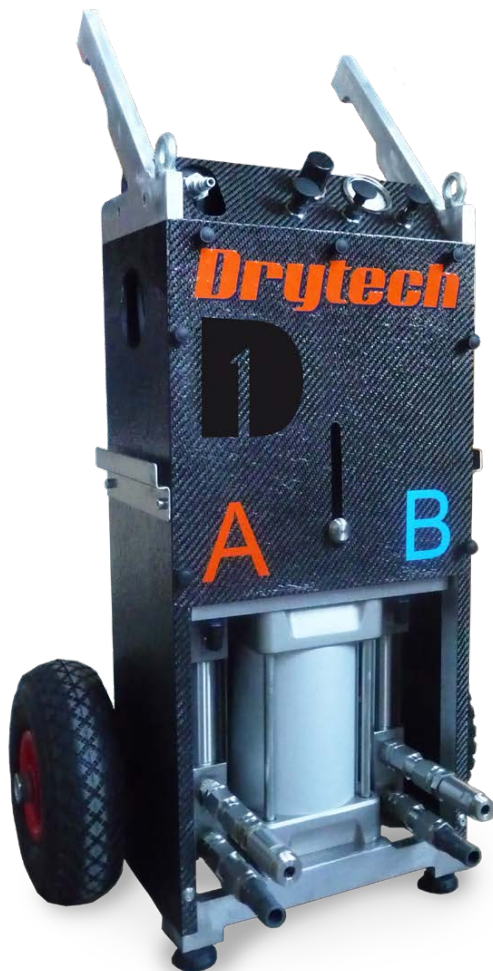

D1 THERMO D2 PEDAL LOW PRESSURE



D1 THERMO

DRYflex drum heating system for injections in environments with temperatures from -2 to 12 °C. To inject resin properly it's mandatory there is no ice in the concrete cracks.



D2 PEDAL

Low pressure bi-component injection machine (for example for waterproofing PVC crossings).

D3 PMMA D4 CHEMICAL BARRIER



D3 PMMA
PMMA injection machine

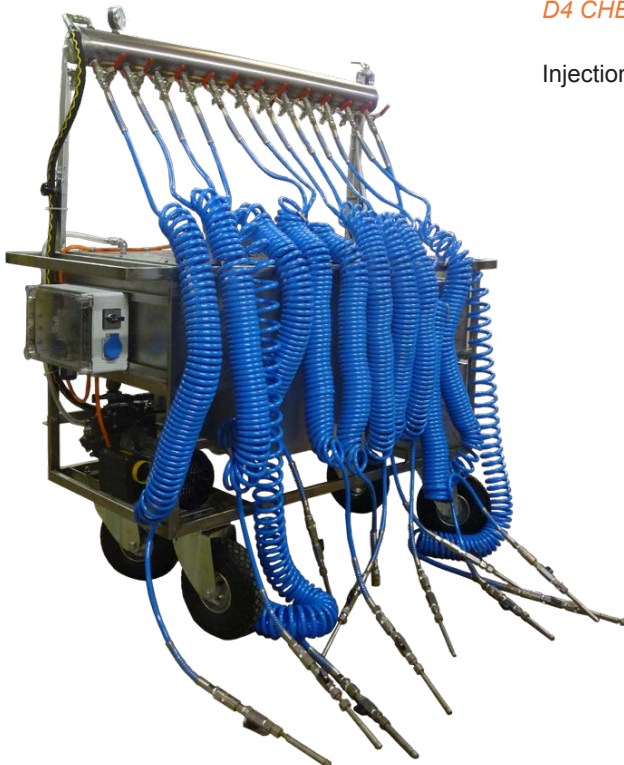

D4 CHEMICAL BARRIER + DRYsoil + DRYveil

Injection machine for veiling, soil consolidation and horizontal barrier injection.

DRYTECH RESTORATION

EX-POST GASKET FOR SYSTEM PIPES AFFECTED BY LEAKS

STOP WATER YES, BUT NOT THE POWER SUPPLY

If a plant pipe becomes permeable, the water can flow inside the pipe towards the interior of the building.

The DRYset Ex-post Gasket is designed to seal pipes that already contain cables or pipes, with a water pressure of up to 3 or 8 bar, without the need to remove the cables or disconnect the power supply.

Each Ex-post Gasket is custom made according to the type and diameter of the pipe, as well as the number and diameter of the cables inside the pipe.

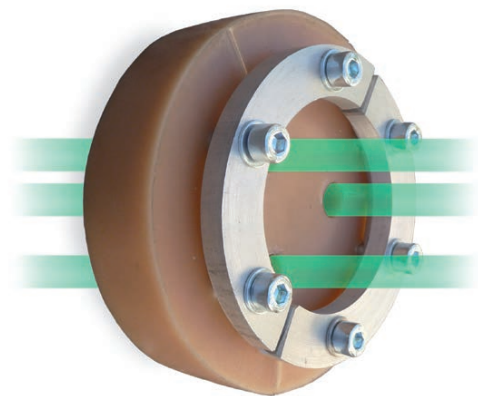
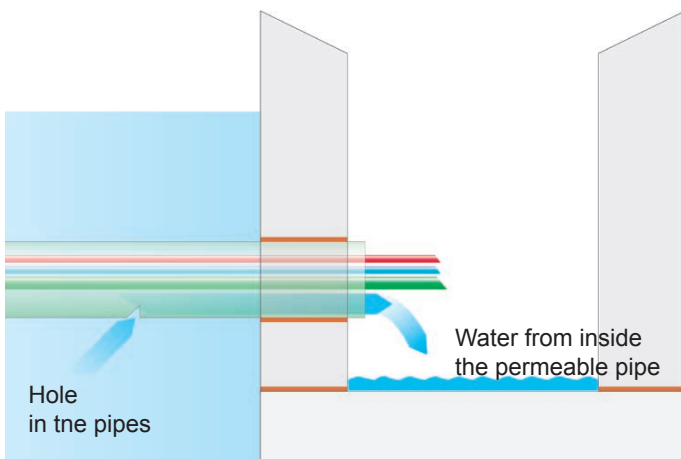

FOR HIGH REQUIREMENTS UP TO 8 BAR PRESSURE

The Duo System allows sealing up to 8 bar if required, by creating a central cavity that is provided with a DRYflex injection.

SEALING PLUGS

Sealing plugs are taylor made on pipe diameter as well.

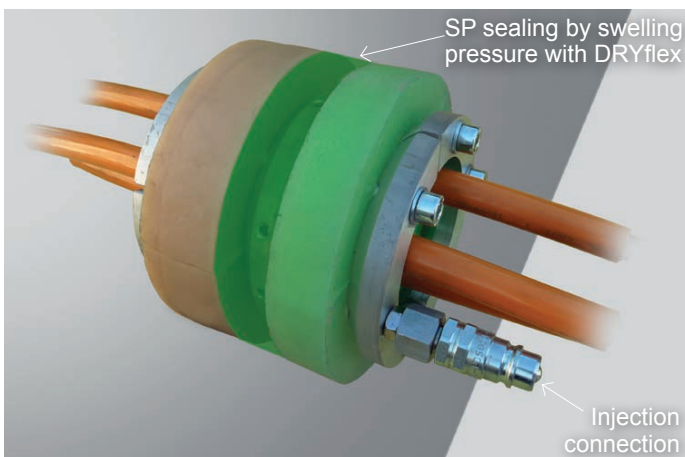
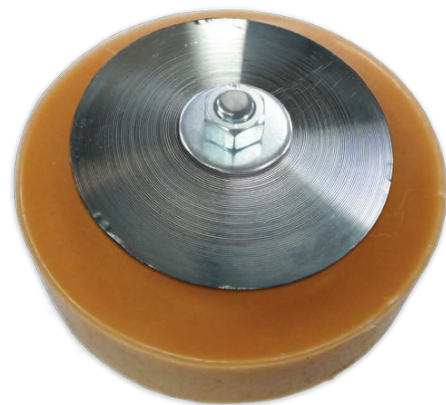
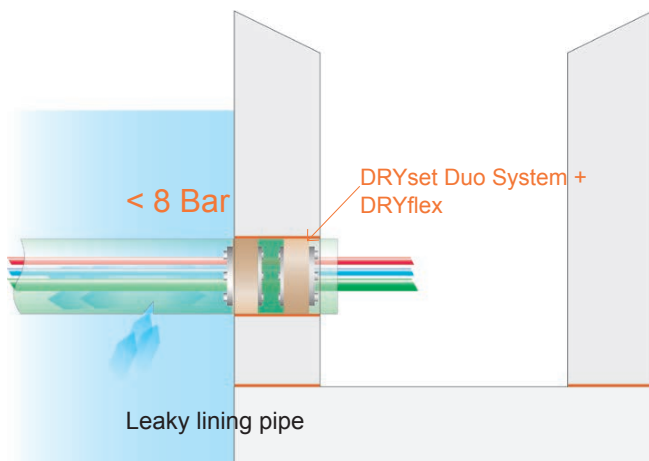

DRYCOAT THE BEST SOLUTION ON THE MARKET

THE LPR LIQUID POLYMER RESIN FOR WATERPROOFING AND HIGH ARCHITECTURAL REQUIREMENTS

A FLEXIBLE, WATERPROOF SURFACE

A 2-component PMMA resin coating with a thickness of up to 3.5 mm.

Drycoat is a flexible, fiber-reinforced polymethylmethacrylate with short drying times with ideal workability and hardening times.

A waterproof flexible liquid membrane for surface waterproofing, ideal for connection to turn-ups at vertical surfaces, columns, water drains and gutters, windows, doors, construction joints and movement joints.

A SYSTEM THAT WORKS BECAUSE IT SATISFIES THE REQUIREMENTS OF CONSTRUCTION PHYSICS

With a hardening time of about 20 minutes, the system can be applied in a short time after the substrate is prepared, and the speed means that capillary moisture, which causes bubbling, can be avoided.

The system and its elements such as primer, resin, texture and final coatings are permeable to vapor diffusion and able to absorb thermal movements of different materials and cracks.



THE OSMOTIC DIFFUSION IS THE BIGGEST CHALLENGE OF ALL RESIN TOPCOATS

The diffusion of water from hot too cold from the bottom to the top carries moisture through all elements that are not vapor-tight (e.g., glass, metals). Many manufacturers to ensure good adherence to the substrate use Epoxy based primers. Unfortunately, moisture diffusion seals under their layer by accumulating water in the pores of the priming surface. During the winter frost causes a micro-destruction that in turns causes loss of adhesion, at that point the water continues its way up and even the best resin will be affected.

THE BEST EXAMPLE OF FAILURE TO COMPLY WITH PHYSICAL REQUIREMENTS IS THE COLLAPSE OF BRIDGES WHERE MAINTENANCE IS NOT CARRIED OUT?

The installers of bituminous waterproofing membranes for a long time, on bridges have laid the membranes with a bituminous primer, without removing the film of cement, then they started to mill the surfaces, after which they tried to use an epoxy primer in one layer and then in two layers. Even today, the basics of the physics of construction are not being respected. In certain situations, a waterproofing system must have adequate osmotic pressure diffusion. In renovations, e.g., of bridges, the corrosion of the reinforcement was so severe that the top protective layer of concrete was removed, and new reinforcement was required.

THE MORE THEY SPEND, SOMETIMES THE LESS THEY SPEND

Where States have been careful and maintenance has been carried out on time, they have been able to spend the budgeted money, where maintenance has not been carried out, failures have occurred with serious consequences such as the collapse of the structure or excessive repair costs.

RESTORATION

During restoration work, Drycoat can be applied directly to an existing surface. No special preparation work or removal of old tiles is required.

THE DIFFERENT APPLICATIONS FIELDS

Drycoat is used for waterproofing terraces, balcon, porticos, passerelles, inverted roofs, showers, tiled swimming pools, plant-beds, parking facilities, ramps, roadsigns, vertical connections with bituminous and synthetic materials,

Drycoat can be used directly as a walkable and Trafficable surface and has a variety of aesthetic solutions, in granite granules or colors. For bonding tiles or granite covering, it is recommended to use hydrophilic binders.

SURFACE RENOVATION

Drycoat if the guidelines are followed can be applied directly to an existing surface without removal of the old tiles.

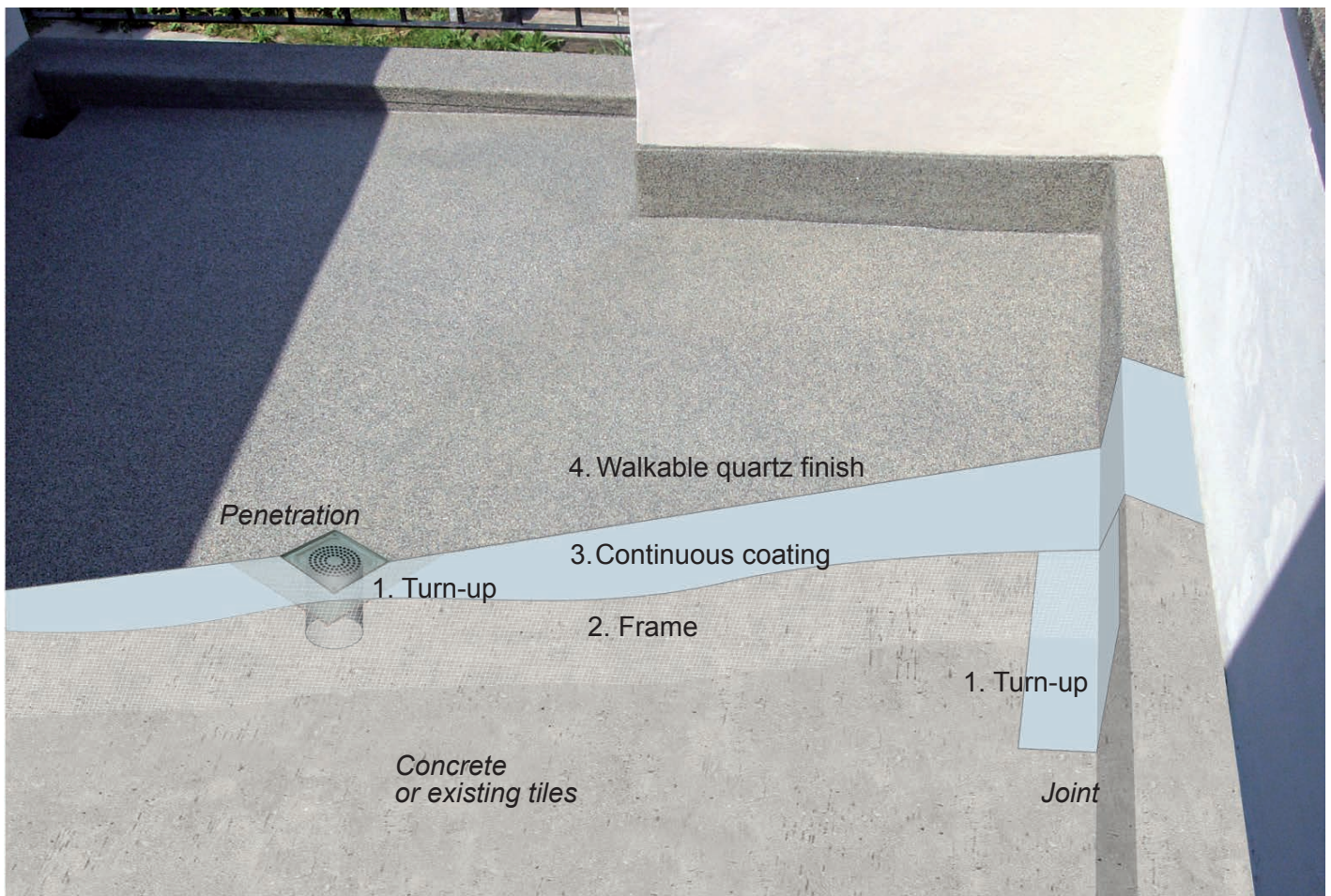

DRYCOAT

TYPES OF SURFACES

- > Quartz sprinkle for tiled surfaces.
- > Anti-slip with quartz 0.2-0.4mm sealed with colored Finish
- > Non-slip with granite granulate 0.5-1.0 mm sealed with transparent or satin Finish.



FINISHING RESINS



RAL 7032



RAL 7043



RAL 7037



RAL 7031



RAL 7035

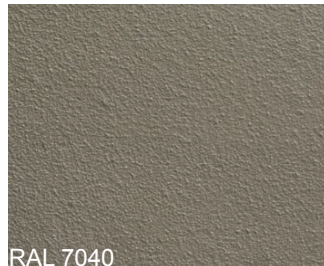

RAL 7040



RAL 9010



RAL 7030

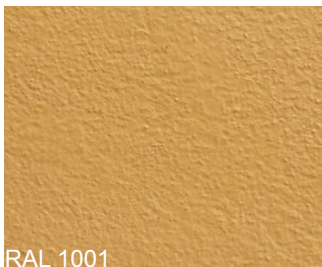

RAL 1001

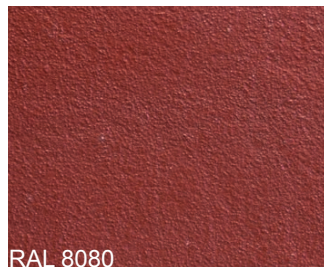

RAL 8080



RAL 1080

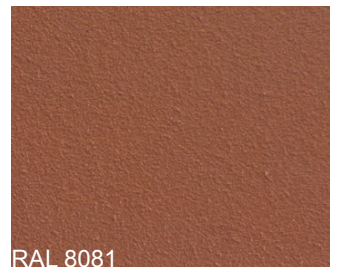

RAL 8081

GRANULES OF GRANITE



CRYSTAL LIGHT



RED



BROWN



ORANGE

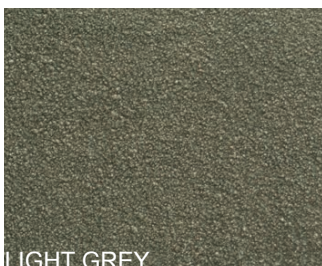

LIGHT GREY



STONE GREY



GRAVEL GREY



TRAFFIC GREY



ANTHRACITE



SALT & PEPPER



WHITE

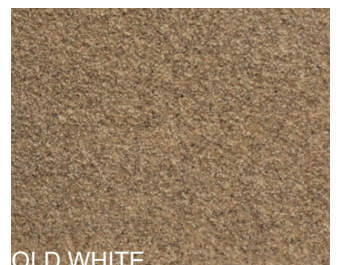

OLD WHITE

TRAINING

KNOW HOW IS THE EFFECTIVE BARRIER AGAINST WATER

DRYTECH OFFERS ITS KNOW-HOW OF ALMOST 60 YEARS BY PROPOSING TO THE INTERESTED APPLICATORS PRACTICAL AND THEORETICAL COURSES.

Each participant will learn the methodology of implementation of the systems, will receive the texts and working times to make offers and will receive a personalized manual.

Drytech Tank Engineering Course				
Languages	Objective	Unit		€
English, German, Italian, French	Design of the waterproof structure and consultancy for the structural engineer and the architect	1½÷2 days	Per day per participant	4'500
		1½÷2 days	Per day for each additional participant	2'500

Drytech Tank Engineering Know-how dossier				
The training course includes the Engineering Manual:				
<ul style="list-style-type: none"> > Estimate template and information about details > Design techniques and solutions > Catalog details for autocad design > Mix design of waterproof concrete and fundamental factors 				

Training course for the construction of the DrytechTank				
Languages	Objective	Unit		€
English, German, Italian, French	Theoretical and practical instructions for the application and installation of Drytech tank systems, with site exercises. Calculation of installation times and commercial offer.	1½÷2 days	Per day per participant	4'500
		1½÷2 days	Per day for each additional participant	1'625

Technical Dossier Drytech Tank				
The training course includes the Drytech Tank Construction Manual				

Training course for Injection Technique for restoration				
Languages	Objective	Unit		€
English, German, Italian, French	Injection technique for new construction and restoration. Calculation of installation times and commercial offer.	1 day	Per day per participant	3'500.-
		1 day	Per day for each additional participant	1'625.-

Training course for the installation of Drycoat waterproofing resin for surfaces				
Languages	Objective	Unit		€
English, German, Italian, French	Installation technique. Calculation of installation times and commercial offer.	1 day	Per day per participant	3'500.-
		1 day	Per day for each additional participant	1'625.-

The company's evolution from the Krattiger generation to the modern Drytech®: Quality and family passion since 1963.

- 1963** Reinhard Krattiger founds the autonomous waterproofing company in Basel, and opens a branch in the Tessin, Southern Switzerland.
- 1978** Andreas and Roger Krattiger join their father's company.
- 1984** Roger Krattiger takes over the Tessin branch named "Krattiger Insulation and Technical Constructions" and Andreas Krattiger takes over the Basel branch named „Krattiger Insulation and Construction Techniques“.
- 1986** Krattiger Insulation and Construction Techniques becomes a licensee of the Rascor Group.
- 1999** Andreas Krattiger takes over the Ticino branch and founds in the same year the first Italian subsidiary in Como.
- 2006** Andreas Krattiger creates the Drytech Group together with German entrepreneur Frank Gerst.
The Group expands in various European countries and opens up numerous branches in Germany, Austria, Liechtenstein, Italy and Switzerland.
Drytech patents the White Tank System® for the waterproofing of new constructions and with the Restoration Systems realizes interventions of international importance.
The Research and Development Laboratory starts in Bedano, Switzerland.
The procedure for testing and certifying DRYflex resins and DRYset products is also started.
- 2015** Inauguration of the Drytech plant for the production of DRYflex Resin, Bedano (Ticino).
- 2015** Development of the foreign market through application partners in Northern Europe and South America.
- 2017** Creation of Drytech International for the marketing and sale of Drytech solutions and products in new markets and for the training and management of certified applicators.

Swiss quality Drytech Waterproofing systems Made by waterproofers for waterproofers.

Being waterproofers has made our systems safer, more practical and more convenient.

But there is more: it is because we are waterproofers, that in the 1990s we decided to develop our own system, which would overcome the limits and weaknesses of traditional waterproofings.

If it is true that work and real problems shape the solutions, we can say that the construction site was, is and will be our first research laboratory.

This is the reason why more and more applicators choose Drytech solutions all over the world.

ARGENTINA
Buenos Aires

AUSTRALIA
Alexandria

DENMARK
Copenhagen

GERMANY
Neustadt Weinstrasse

ITALY
Como

HOLLAND
Vianen and Soest

IRELAND
Naas

UK
London

SOUTH KOREA
Seoul