

Drytech[™]

Waterproofing System Engineering

WATERPROOF DIAPHRAGMS DRYTECH TECHNOLOGY

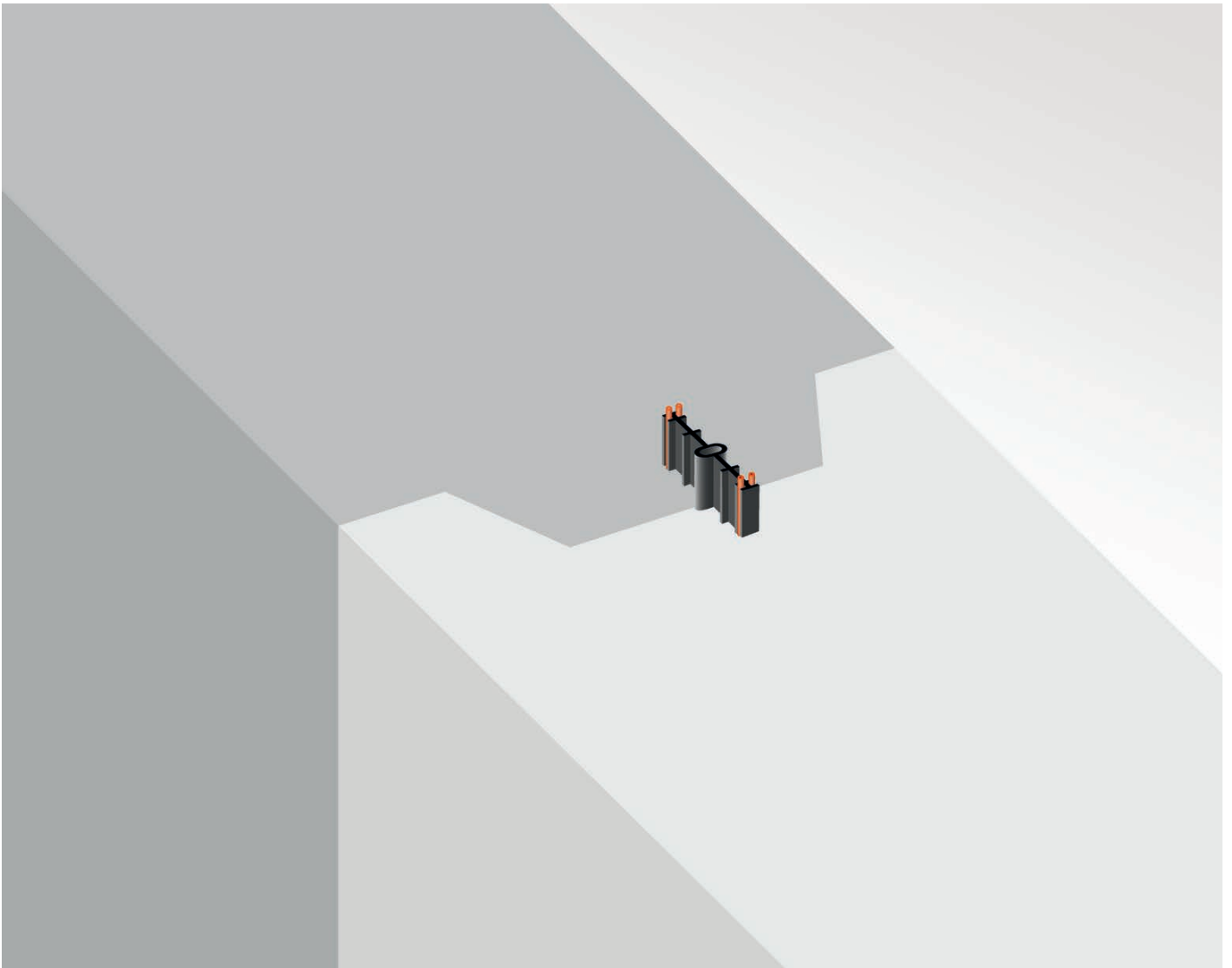

DRYTECH DIAPHRAGMS

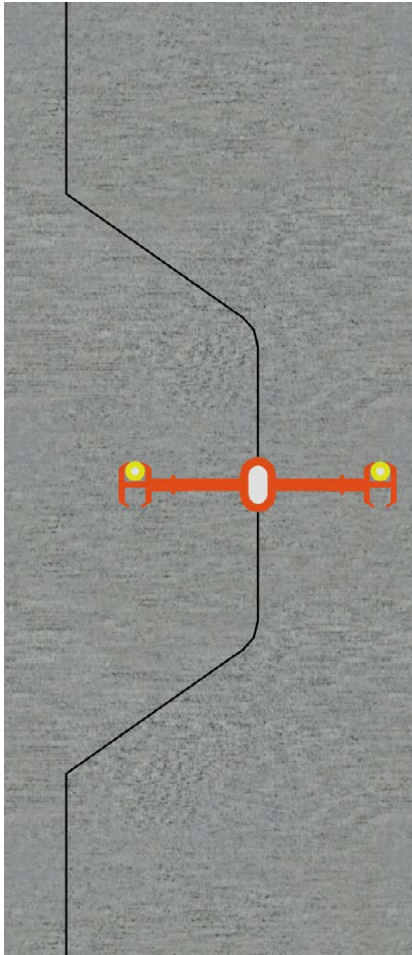
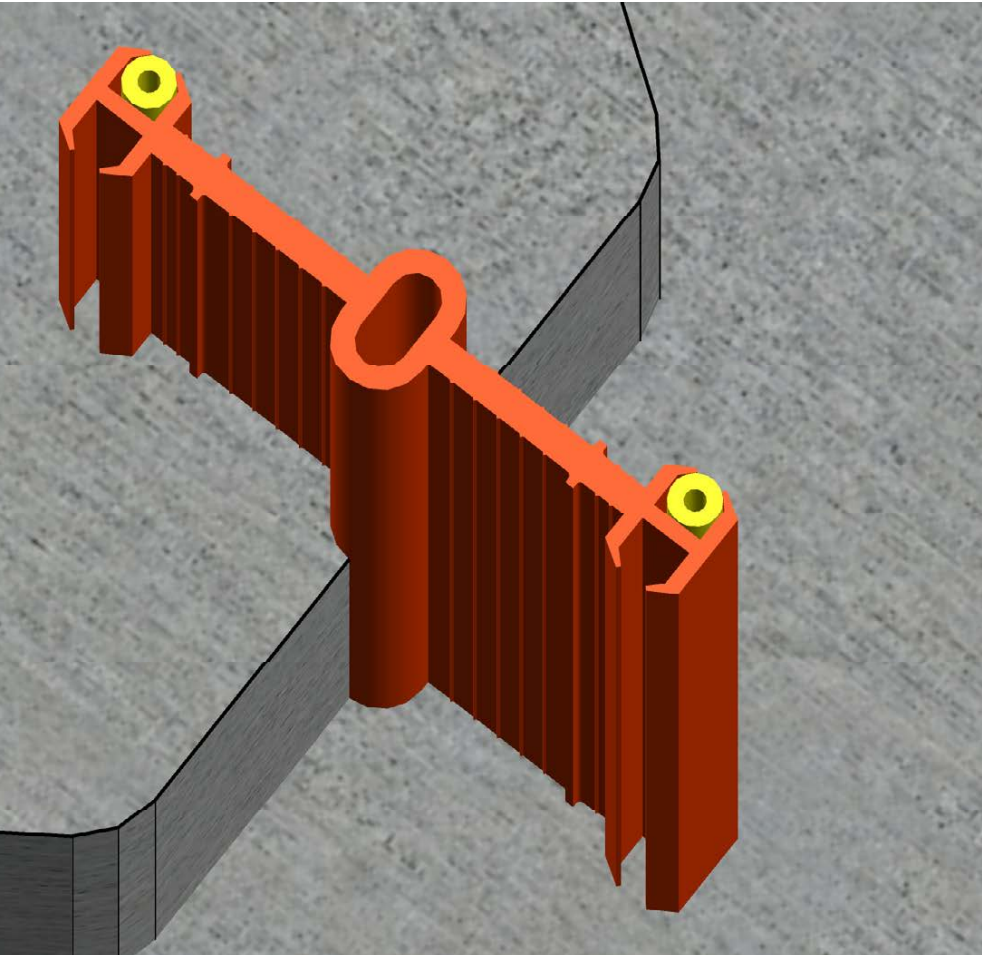
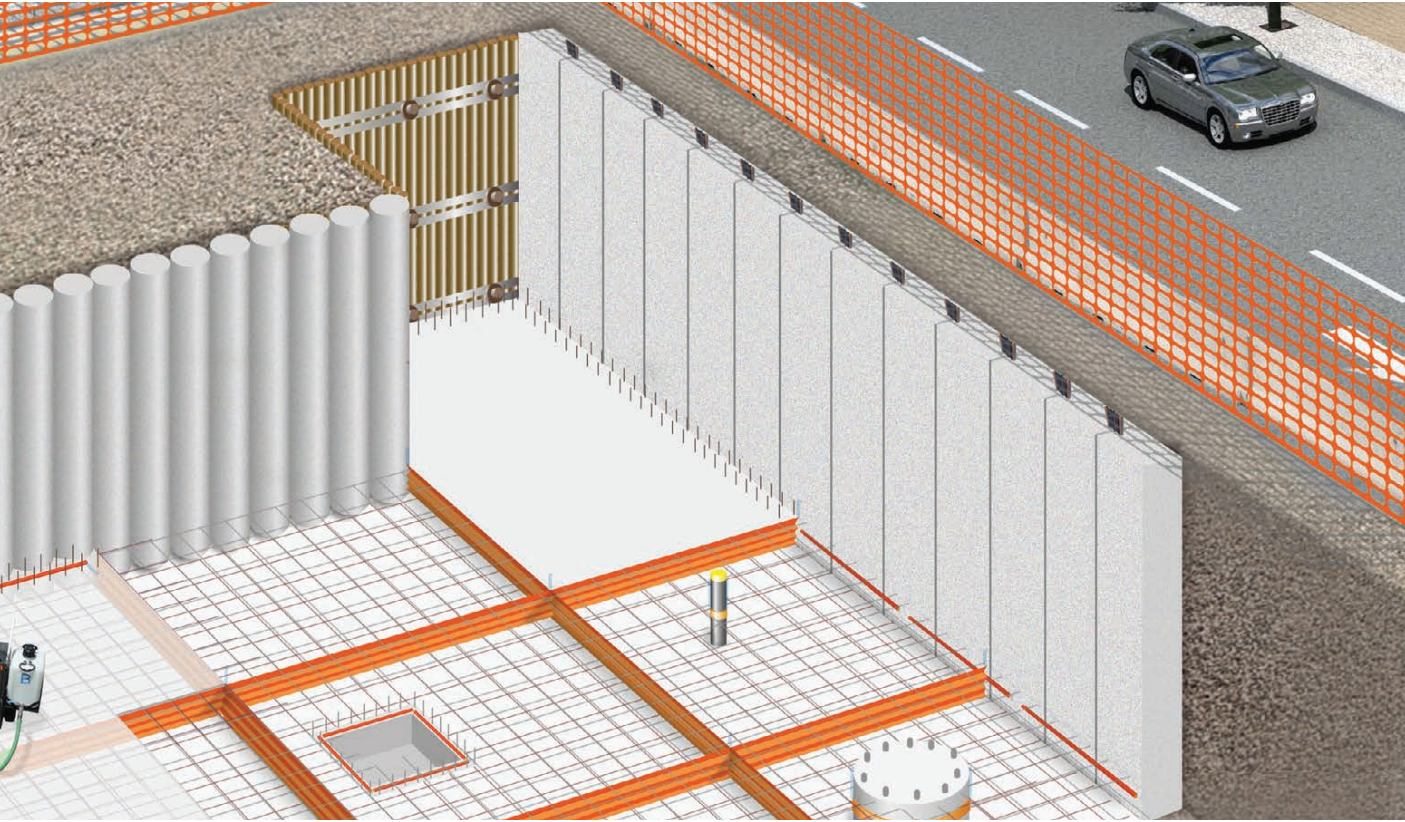

Waterproof basement without lining walls

The diaphragms can be made directly waterproof with the insertion of DRYset Injectable Waterstop Tapes in the joints between the septa.

The waterproofing of the diaphragm overcomes the need for waterproof lining walls.

It is a solution adopted, for example, in basements where the volume must be exploited to the maximum, for regulatory or economic reasons.

The special Waterstop DRYset for diaphragms are equipped with micro-perforated cannulas - accessible from inside the structure - to inject the entire thickness of the joint with DRYflex expanding resin.

Furthermore, the system allows maintenance re-injections in the face of any infiltrations.



APPLICATION OF THE DRYSET INJECTABLE WATERSTOP TAPE



1. Shaped sheet pile.

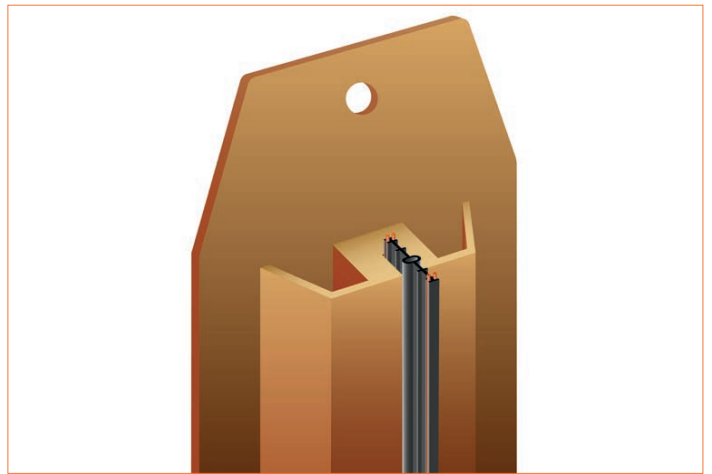

2. Injectable Waterstop Tape Housing.

5. Jet next septum.

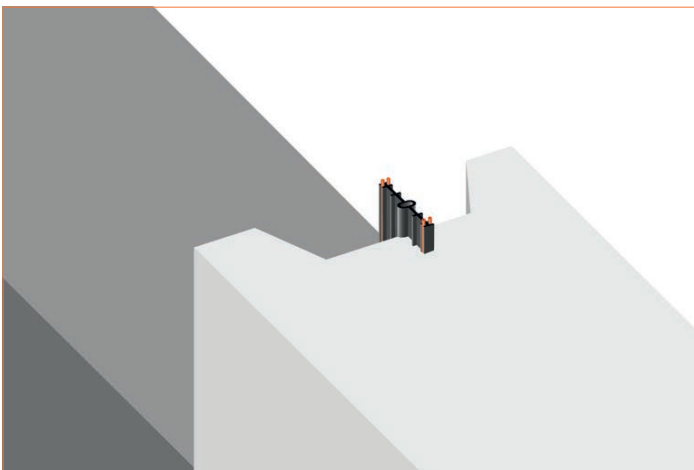

6. Joint waterproofed perpendicularly by the Waterstop DRYset Tape.

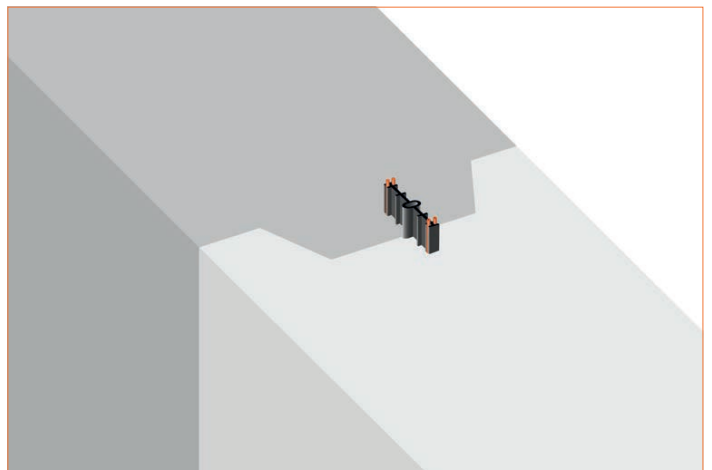

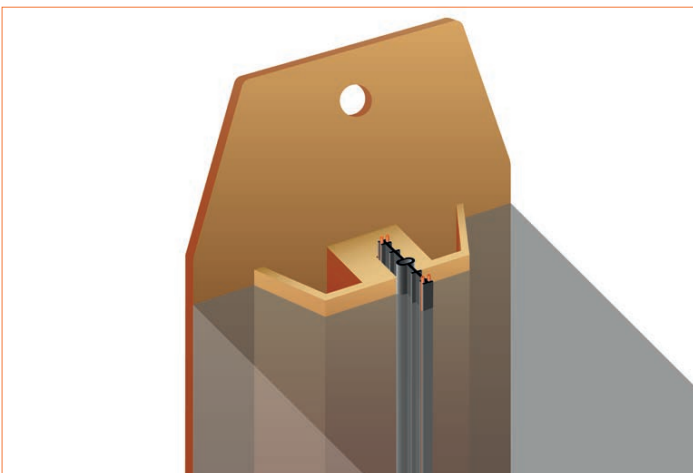

3. Casting of the first sector.

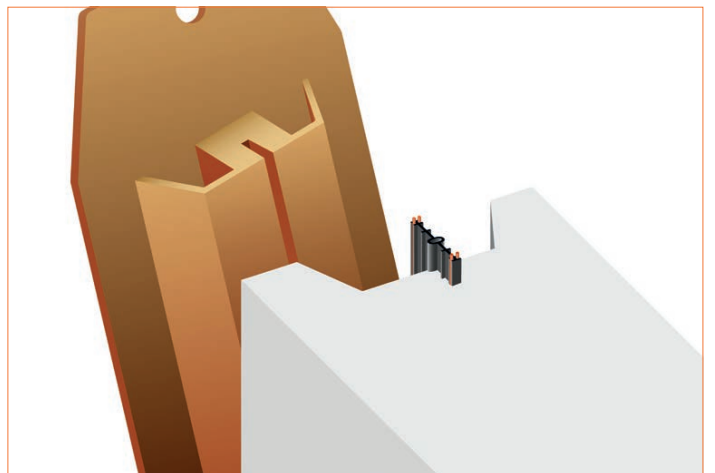

4. Removal of the sheet pile.

7. Joint waterproofed longitudinally with the injection of DRYflex resin.

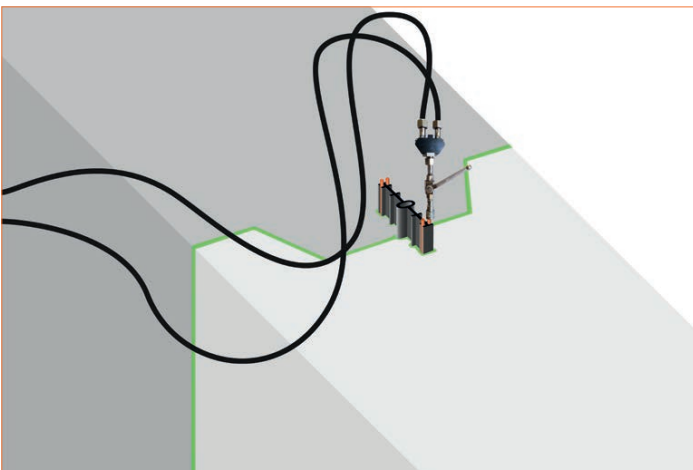

8. Waterstop cannulas junction box for any maintenance injections.

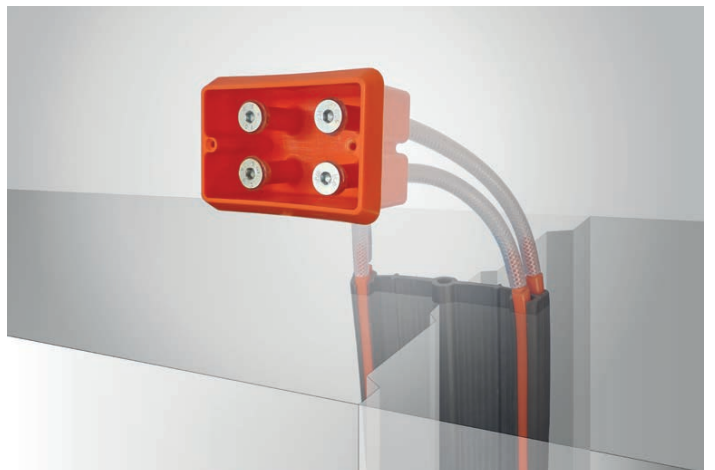

SECTIONS AND OPERATIONAL PRESCRIPTIONS

Reinforcement section

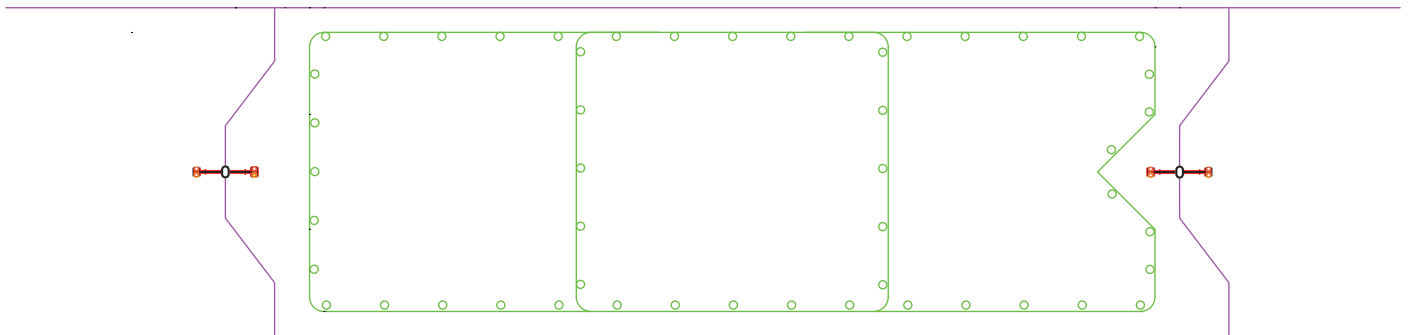

Junction box section

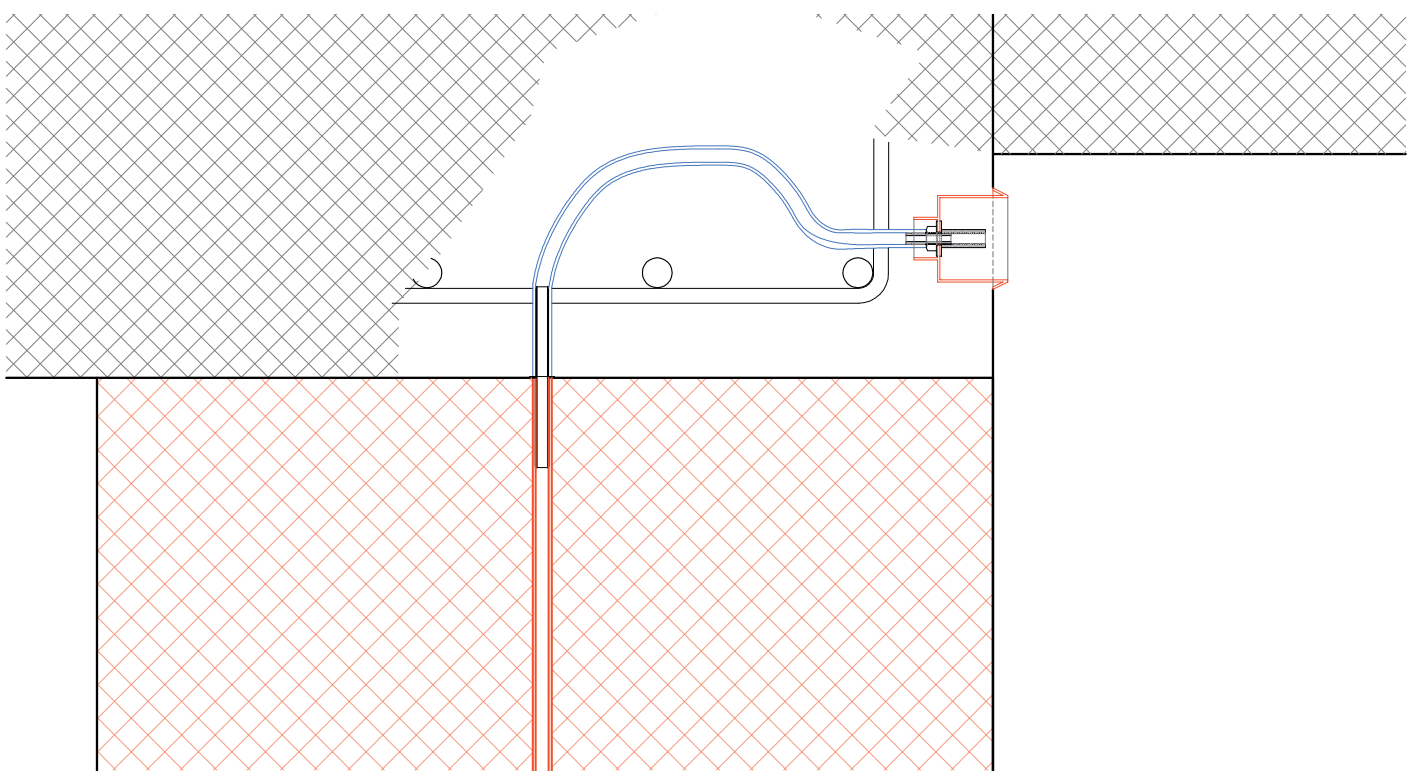

Operational requirements

1. The Drytech Injectable Waterstop must be inserted in the special guide of the sheet piling, so that it does not come out of its seat during the casting operations and so that it is not torn off at the moment of breaking.
2. During the excavation operation for the formation of the diaphragm, de-sand the bentonite mud (max sand content allowed before casting: 3%). In the case of particularly fine soils, consider regenerating the bentonite mud more frequently than in standard conditions.
3. The sheet pile sealing in the waterstop position must be suitably treated with release oil on the side not in contact with the ground, before casting the diaphragm.
4. The reinforcement cages of the diaphragms must be shaped near the waterstop as per Drytech executive details, respecting the maximum steps of 15 cm vertically and 20 cm horizontally.
The shaping of the cages near the Drytech waterstop must be extended over the entire height of the panel, in order to allow easy insertion of the cages to be used at the bottom of the excavation.
5. Provide fiber cement spacers (minimum thickness 50 mm) on the side faces of the reinforcement cages.
6. The first casting must be made with a tuboforma, minimum internal diameter 150 mm, raised about 10 cm from the bottom of the excavation.
The pipe must be kept immersed in the concrete for at least 3 meters to avoid segregation or cracking of horizontal joints resulting from the mixing of concrete and bentonite mud.
The rising speed of the casting surface must not be less than 3 meters / hour in order to avoid the formation of accidental casting joints.
7. The removal of the sheet piling must take place through an initial downward movement of the same in order to allow the detachment of the casting surface without causing the waterstop to tear.
Then proceed with the extraction of the side panel, possibly moving it both sideways and upwards.
8. Avoid the contextual formation of double panels in line, in order to avoid the risk of the formation of cracks in the vertical sections that are not reinforced and without water tightness devices.

SPECIFICATION ITEMS

SUPPLY AND INSTALLATION

Supply of Waterstop Drytech HDA 160 mm PVC injectable tape for joints between diaphragms, positioned on site by the company executing the works using a special Bachy-type sheet pile.

The latter allows the exact positioning of the joint, the protection of the same during the construction of the adjacent diaphragm and the construction of the excavation of the next panel in perfect adherence to the previous one by means of a special anchor rail of the clamshell.

DRYFLEX INJECTION

Subsequent injection with DRYflex bi-component acrylic resin, carried out with special equipment through the micro-perforated tubes of the tape by Drytech specialized personnel, to allow the correct diffusion of the waterproofing resin inside the gap between the diaphragms, thus sealing any imperfections of the same (gravel nests, etc ...), and to be able to issue guarantees on the hydraulic seal of the same as per the Civil Code.

These tubes will be accessible by means of injection kits specially housed in the casting of the crowning beam.

MAINTENANCE AND WARRANTY

In order to extend the contractual guarantee to the diaphragm mirrors, instead of the sole hydraulic seal of the joints, it will be the responsibility of the waterproofing system supplier to define the characteristics and mix design of the concrete to be used, in compliance with the resistance and exposure classes provided for project. Likewise, binding indications will be given from this regarding the maximum pitch, both vertical and horizontal, of the reinforcement of the cages of the diaphragms as well as the prescription of specific construction reinforcements to protect the aforementioned waterstop.

PLATEA-DIAPHRAGM CONNECTION

The waterproofing works in correspondence with the platea-diaphragm connection provide for the thorough cleaning of the diaphragm surfaces, regularization of any shortcomings or protuberances, elimination of bentonite deposits on the joints, restoration of planarity with non-shrinkage mortars.

Closure with anti-shrinkage mortar of the joint between the segments of the diaphragms and possible treatment of the diaphragm on the graft surface of the base with osmotic mortars.

Subsequent injection, to saturation of the joint between diaphragm segments, in the thickness of these up to the waterstop running in the middle, for the graft portion of the slab, to be carried out on each joint of the facing.

Positioning of the connecting rods required by the structural project, grouted with the use of epoxy resin or vinylester suitable for the purpose, in the number, diameter and pitch provided.

Supply and installation of the DRYset casting channel, positioned by nailing the diaphragm, according to the manufacturer's specifications.

Following the casting and curing of the injection with special equipment of two-component acrylic resin DRYflex 1, to saturation of the return channels, programmed cracking elements, sleeves on through bodies or suitably prepared pipes, and sealing of the joints between segments of diaphragms with residual infiltrations.

The works described above will be covered by watertight guarantees according to the Civil Code with any insurance coverage stipulated with a primary insurance company.

Referenze

- | | |
|---|---|
| > GRADO (GO) lotto Due Rose | 2 underground levels, diaphragm walls 110 m |
| > CAORLE (VE) via Porto San Margherita | 2 underground levels, diaphragm walls 370 m |
| > ALBENGA (SV) via Giovanni XXIII | 2 underground levels, diaphragm walls 215 m |
| > SAN DONATO MILANESE (VE) via Trieste | 2 underground levels, diaphragm walls 120 m |
| > IMPERIA (IM) ex-cinema Dante | 2 underground levels, diaphragm walls 130 m |
| > PIETRA LIGURE (SV) via Canneva | 1 underground level, diaphragm walls 105 m |
| > MILANO (MI) piazza Sant' Ambrogio | 5 underground levels, diaphragm walls 430 m |
| > SAN DONATO MILANESE (VE) via Greppi | 1 underground level, diaphragm walls 270 m |
| > JESOLO (GO) Piazza Marina | 1 underground level, diaphragm walls 90 m |
| > CESENATICO (FC) Lungomare | 1 underground level, diaphragm walls 180 m |
| > PARMA (PR) via del Conservatorio | 2 underground levels, diaphragm walls 260 m |
| > PESCARA (PE) via Tasso | 2 underground levels, diaphragm walls 150 m |
| > RICCIONE (RN) via Baracca | 1 underground level, diaphragm walls 60 m |
| > PAULLO (MI) via Verdi | 1 underground level, diaphragm walls 100 m |
| > PESARO (PU) via Battisti | 1 underground level, diaphragm walls 80 m |
| > SAN DONATO MILANESE (MI)
piazza Vanoni | 1 underground level, diaphragm walls 830 m |

PARKING

BASILICA DI SANT'AMBROGIO, MILAN



In Piazza Sant'Ambrogio, in Milan, the construction company Borio Mangiarotti S.p.A. built a five-storey underground car park.

Drytech has designed a waterproofing system for the diaphragm based on DRYset Injectable Waterstop Tapes. This Drytech patent is an evolution of the classic waterstop tape which, equipped with pre-drilled tubes, makes it possible both to inject the joint throughout the thickness of the diaphragm and to maintain it over time in the face of any infiltrations, always with resin injections.

The construction of the waterproof diaphragm avoided the lining wall, ensuring compliance with the minimum internal volumes required by law.

The diaphragm of the parking lot that flanks the Milanese basilica drops to a depth of 22.70 meters and the laying of a sheet pile of this size required special care by the company's technicians, to ensure perfect alignment of the joints. The perpendicularity is in fact preparatory to the correct detachment of the sheet piling itself from the strip, once it has been incorporated into the concrete of the partition.

Once the casting is complete, the sheet piling is extracted, prepared with a new belt and repositioned for the casting of the next partition.

The pre-drilled pipes of the Drytech Waterstop Tape are connected to junction boxes placed in the crowning beam, which will be accessible from inside the car park.

The practicality of the waterstop tape is therefore associated with the possibility of carrying out maintenance on the diaphragm at any time, by intervening from inside the structure, without excavation or demolition and, above all, without having to close the car park.

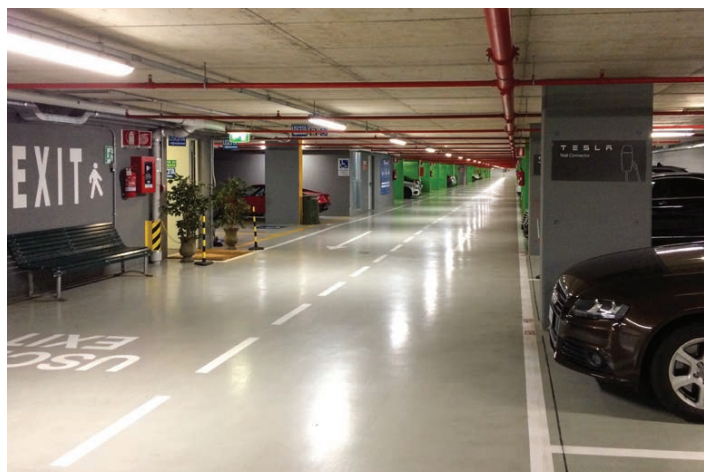
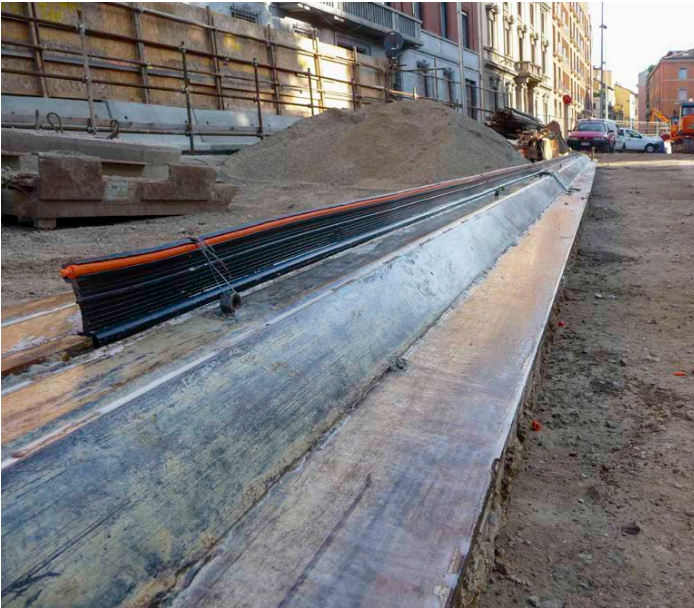

DRYTECH

ITALY

Drytech Italia Impermeabilizzazioni Srl
Via Valtellina 6
I-22070 Montano Lucino CO
+39 031 47 12 01
italia@drytech.ch

SWITZERLAND

Drytech SA
Via Industrie 12
CH-6930 Bedano TI
+41 91 960 23 40
ticino@drytech.ch

GERMANY

Drytech GmbH
Im Altenschemel 39a
D-67435 Neustadt
+49 6327 97 22 50
info@drytech-germany.de

BERLIN

Motzener Straße 12-14
D-12277 Berlin
+49 30 475 954 05
info@abdichtung-in-berlin.de

FRANKFURT

Freudenthaler Straße 39
D-65232 Taunusstein
+49 6128 306 688
frankfurt@drytech-germany.de

MUNICH

Landshuter Allee 8-10
D-80637 München
+49 89 545 582 05
muenchen@drytech-germany.de

IRELAND

Drytech Waterproofing Ltd.
Spring Garden Lodge - Sallins Road
Naas, Co. Kildare.
+353 45 83 11 60
ireland@drytech.ie

UK

Drytech Waterproofing Ltd.
Berkeley Square House
W1J 6BD, London
+44 20 3959 8611
uk@drytech.ch

CANADA

Drytech Waterproofing Ltd
30 Street SE
7032 Calgary - Alberta
+1 403 230 3050
canada@drytech.ca

**CERTIFIED
PARTNERS**

BASEL

Mareas AG
Gebäudeabdichtung
Bottmingerstrasse 27
4102 Binningen
+41 61 525 15 15
info@mareas.ch

DENMARK

Christiansen & Essenbaek A/S
Ejby Industrivej 80
DK-2600 Glostrup
+45 88 888 203
info@ceas.dk

SOUTH ITALY

Edilo Srl
Via E. Gianturco 62-64
I-80146 Napoli NA
+39 081 734 94 33
campania@drytech.ch

INTERNATIONAL PARTNERS

international@drytech.ch
ARGENTINA **FRANCE**
AUSTRALIA **SOUTH KOREA**
BRASIL

www.drytech.ch

